



---

# **FINISH MOWER**

## **OPERATION AND ASSEMBLY MANUAL**

# INTRODUCTION

## TO THE OWNER:

Read this manual before operating your equipment. Keep this manual handy for ready reference. Require all operators to read this manual carefully and become acquainted with all adjustments and operating procedures before attempting to operate the equipment. Replacement manuals can be obtained from your selling dealer.

The equipment you have purchased has been carefully engineered and manufactured to provide dependable and satisfactory use. Like all mechanical products, it will require cleaning and upkeep. Lubricate the unit as specified. Please observe all safety information in this manual and safety decals on the equipment.

Use only genuine service parts. Substitute parts will void the warranty and may not meet the required standards for safe and satisfactory operation.

Throughout this manual, the term **IMPORTANT** is used to indicate that failure to observe procedures can cause damage to equipment. The terms **CAUTION**, **WARNING** and **DANGER** are used in conjunction with the Safety-Alert Symbol, (a triangle with an exclamation mark), to indicate the degree of hazard for items of personal safety.



**This Safety-Alert Symbol indicates a hazard and means ATTENTION! BECOME ALERT! YOUR SAFETY IS INVOLVED!**



**DANGER**

**Indicates an imminently hazardous situation that, if not avoided, will result in death or serious injury.**



**WARNING**

**Indicates a potentially hazardous situation that, if not avoided, could result in death or serious injury, and includes hazards that are exposed when guards are removed.**



**CAUTION**

**Indicates a potentially hazardous situation that, if not avoided, may result in minor or moderate injury.**

**IMPORTANT**

**Indicates that failure to observe can cause damage to equipment.**

**NOTE**

**Indicates helpful information.**

## IT IS THE PURCHASER AND/OR OPERATOR'S RESPONSIBILITY TO....

Read and understand the information contained in this manual.

Operate, lubricate, assemble and maintain the equipment in accordance with all instructions and safety procedures in this manual.

Inspect the equipment and replace or repair any parts that are damaged or worn which under continued operation would cause damage, wear to other parts, or cause a safety hazard.

Return the equipment or parts to the authorized dealer, from where it was purchased, for service or replacement of defective parts that are covered by warranty. (Manufacturer may inspect equipment or parts before warranty claims are honored.)

Payment of all costs incurred by the dealer for traveling to or transporting the equipment for warranty inspection and or claims.

## **TO THE PURCHASER:**

This manual contains valuable information about your new Finish Mower. It has been carefully prepared to give you helpful suggestions for operating, adjusting, servicing and ordering repair parts.

Keep this manual in a convenient place for quick and easy reference. Study it carefully. You have purchased a dependable and sturdy mower, but only by proper care and operation can you expect to receive the service and long life designed and built into it.

Sometime in the future your mower may need new parts to replace those that are worn or broken. If so, go to your dealer and provide him with the model and part number.

## **CUSTOMER INFORMATION**

**Name** \_\_\_\_\_

**Purchased From** \_\_\_\_\_

**Date Purchased** \_\_\_\_\_

**Model No.** \_\_\_\_\_

**Serial No.** \_\_\_\_\_

## TABLE OF CONTENTS

Introduction .....	4
Safety .....	5-9
Description .....	10-11
Preparation .....	12
Assembly .....	13-14
Modify PTO Driveline .....	15
Attaching .....	16-17
Detaching .....	17
Operation .....	18-21
Lubrication & Maintenance .....	22-23
Service .....	24-25
Storage .....	25
Troubleshooting Guide .....	26
Torque Specifications .....	27
Parts .....	28-29
Warranty .....	30

### General Information

The purpose of this manual is to assist you in operating and maintaining your finish mower for years of service. Read it carefully. The information and instructions in this manual have been compiled from extensive field experience and engineering data. Some information may be general in nature due to unknown and varying operating conditions. However, through experience and these instructions, you should be able to develop procedures suitable to your particular situation.

The illustrations and data used in this manual were current at the time of printing, but due to possible inline production changes, your machine may vary slightly in detail. We reserve the right to redesign and change the machines as may be necessary without notification.

 **Some illustrations in this manual may show the finish mower with safety shields removed to provide a better view. The finish mower should never be operated with any safety shielding removed.**

**WARNING**

Throughout this manual, references are made to right and left direction. These are determined by standing behind the equipment facing the direction of forward travel. Blade rotation is counter-clockwise as viewed from the top of the mower.

All information, illustrations and specifications in this manual are based on the latest information available at the time of publication. The right is reserved to make changes at any time without notice.

Safety is a primary concern in the design and manufacture of our products. Unfortunately, our efforts to provide safe equipment can be wiped out by an operator's single careless act.

In addition to the design and configuration of equipment, hazard control and accident prevention are dependent upon the awareness, concern, judgment, and proper training of personnel involved in the operation, transport, maintenance and storage of equipment.

It has been said "The best safety device is an informed, careful operator." We ask you to be that kind of operator.

## **TRAINING**

Safety instructions are important! Read all attachment and power unit manuals; follow all safety rules and safety decal information. (Replacement manuals and safety decals are available from your dealer.) Failure to follow instructions or safety rules can result in serious injury or death.

If you do not understand any part of this manual and need assistance, see your dealer.

Know your controls and how to stop engine and attachment quickly in an emergency.

Operators must be instructed in and be capable of the safe operation of the equipment, its attachments, and all controls. Do not allow anyone to operate this equipment without proper instructions.

Never allow children or untrained persons to operate equipment.

## **PREPARATION**

Check that all hardware is properly installed.

Always tighten to torque chart specifications unless instructed otherwise in this manual.

Always wear relatively tight and belted clothing to avoid getting caught in moving parts. Wear sturdy, rough-soled work shoes and protective equipment for eyes, hair, hands, hearing, and head; and respirator or filter mask where appropriate.

Make sure attachment is properly secured, adjusted, and in good operating condition.

Make sure collar slides freely and is seated firmly in tractor PTO spline groove.

Before putting equipment into service, check and adjust driveline length as instructed in Operator's Manual. Driveline must not bottom out or pull apart throughout the full range of the tractor hitch. Do not operate until driveline length is correct.

Make sure driveline shield safety chain is attached as shown in this manual. Replace if damaged or broken. Check that driveline guards rotate freely on driveline before putting equipment into service.

Before starting power unit, check all equipment driveline guards for damage. Replace any damaged guards. Make sure all guards rotate freely on all drivelines. If guards do not rotate freely on drivelines, repair and replace bearings before putting equipment into service.

Inspect all guards and shields before each use. Replace if damaged.

Remove accumulated debris from this equipment, power unit, and engine to avoid fire hazard.

Power unit must be equipped with ROPS or ROPS cab and seat belt. Keep seat belt securely fastened. Falling off power unit can result in death from being run over or crushed. Keep foldable ROPS system in "locked up" position at all times.

A minimum 20% of tractor and equipment weight must be on the tractor front wheels when attachments are in transport position. Without this weight, tractor could tip over, causing personal injury or death. The weight may be attained with a loader, front wheel weights, ballast in tires or front tractor weights. Weigh the tractor and equipment. Do not estimate.

(Safety Rules continued on next page)

(Safety Rules continued from previous page)

Make sure all safety decals are installed. Replace if damaged. (See Safety Decals section for location.)

Make sure shields and deflectors are properly installed and in good condition. Replace if damaged.

Inspect and clear area of stones, branches, or other hard objects that might be thrown, causing injury or damage.

## **TRANSPORTATION**

Power unit must be equipped with ROPS or ROPS cab and seat belt. Keep seat belt securely fastened. Falling off power unit can result in death from being run over or crushed. Keep foldable ROPS system in "locked up" position at all times.

A minimum 20% of tractor and equipment weight must be on the tractor front wheels when attachments are in transport position. Without this weight, tractor could tip over, causing personal injury or death. The weight may be attained with a loader, front wheel weights, ballast in tires or front tractor weights. Weigh the tractor and equipment. Do not estimate.

Always comply with all state and local lighting and marking requirements.

Never allow riders on power unit or attachment.

Do not operate PTO during transport.

Watch for hidden hazards on the terrain.

Do not operate or transport on steep slopes.

Do not operate or transport equipment while under the influence of alcohol or drugs.

## **OPERATION**

Do not allow bystanders in the area when operating, attaching, removing, assembling, or servicing equipment.

Never direct discharge toward people, animals, or property.

Do not operate or transport equipment while under the influence of alcohol or drugs.

Keep hands, feet, hair, and clothing away from equipment while engine is running. Stay clear of all moving parts.

Operate only in daylight or good artificial light. Always comply with all state and local lighting and marking requirements.

Never allow riders on power unit or attachment.

Power unit must be equipped with ROPS or ROPS cab and seat belt. Keep seat belt securely fastened. Falling off power unit can result in death from being run over or crushed. Keep foldable ROPS system in "locked up" position at all times.

Always sit in power unit seat when operating controls or starting engine. Securely fasten seat belt, place transmission in neutral, engage brake, and ensure all other controls are disengaged before starting power unit engine.

Operate tractor PTO at 540 RPM. Do not exceed.

Do not operate PTO during transport.

Look down and to the rear and make sure area is clear before operating in reverse.

Do not operate or transport on steep slopes.

Do not stop, start, or change directions suddenly on slopes.

Use extreme care and reduce ground speed on slopes and rough terrain.

Watch for hidden hazards on the terrain during operation.

(Safety Rules continued on next page)

(Safety Rules continued from previous page)

## ATTENTION! BECOME ALERT! YOUR SAFETY IS INVOLVED!

Stop power unit and equipment immediately upon striking an obstruction. Turn off engine, remove key, inspect, and repair any damage before resuming operation.

Leak down or failure of mechanical or hydraulic system can cause equipment to drop.

### MAINTENANCE

Before dismounting power unit or performing any service or maintenance, follow these steps: disengage power to equipment, lower the 3-point hitch and all raised components to the ground, set parking brake, stop engine, remove key, and unfasten seat belt.

Before performing any service or maintenance, disconnect driveline from tractor PTO.

Before working underneath, carefully read Operator's Manual instructions, disconnect drive line, raise mower, securely block up all corners with jack stands, and check stability. Secure blocking prevents equipment from dropping due to hydraulic leak down, hydraulic system failures, or mechanical component failures.

Do not modify or alter or permit anyone else to modify or alter the equipment or any of its components in any way.

Always wear relatively tight and belted clothing to avoid getting caught in moving parts. Wear sturdy, rough-soled work shoes and protective equipment for eyes, hair, hands, hearing, and head; and respirator or filter mask where appropriate.

Make sure attachment is properly secured, adjusted, and in good operating condition.

Keep all persons away from operator control area while performing adjustments, service, or maintenance.

Never go underneath equipment (lowered to the ground or raised) unless it is properly blocked and secured. Never place any part of the body under neath equipment or between moveable parts even when the engine has been turned off. Hydraulic system

leak down, hydraulic system failures, mechanical failures, or movement of control levers can cause equipment to drop or rotate unexpectedly and cause severe injury or death. Follow Operator's Manual instructions for working underneath and blocking requirements or have work done by a qualified dealer.

Make certain all movement of equipment components has stopped before approaching for service.

Frequently check blades. They should be sharp, free of nicks and cracks, and securely fastened.

Do not handle blades with bare hands. Careless or improper handling may result in serious injury.

Your dealer can supply genuine replacement blades. Substitute blades may not meet original equipment specifications and may be dangerous. Also, blade bolts must be changed when replacing blades.

Tighten all bolts, nuts, and screws to torque chart specifications. Check that all cotter pins are installed securely to ensure equipment is in a safe condition before putting unit into service.

Make sure all safety decals are installed. Replace if damaged. (See Safety Decals section for location.)

Make sure shields and deflectors are properly installed and in good condition. Replace if damaged.

### STORAGE

Block equipment securely for storage.

Keep children and bystanders away from storage area.

Follow manual instructions for storage.

Always use a tractor to position equipment for storage. Never attempt to move equipment by hand.

# SAFETY AND INSTRUCTION DECALS

ATTENTION! BECOME ALERT! YOUR SAFETY IS INVOLVED!

Replace Decals Immediately if Damaged!

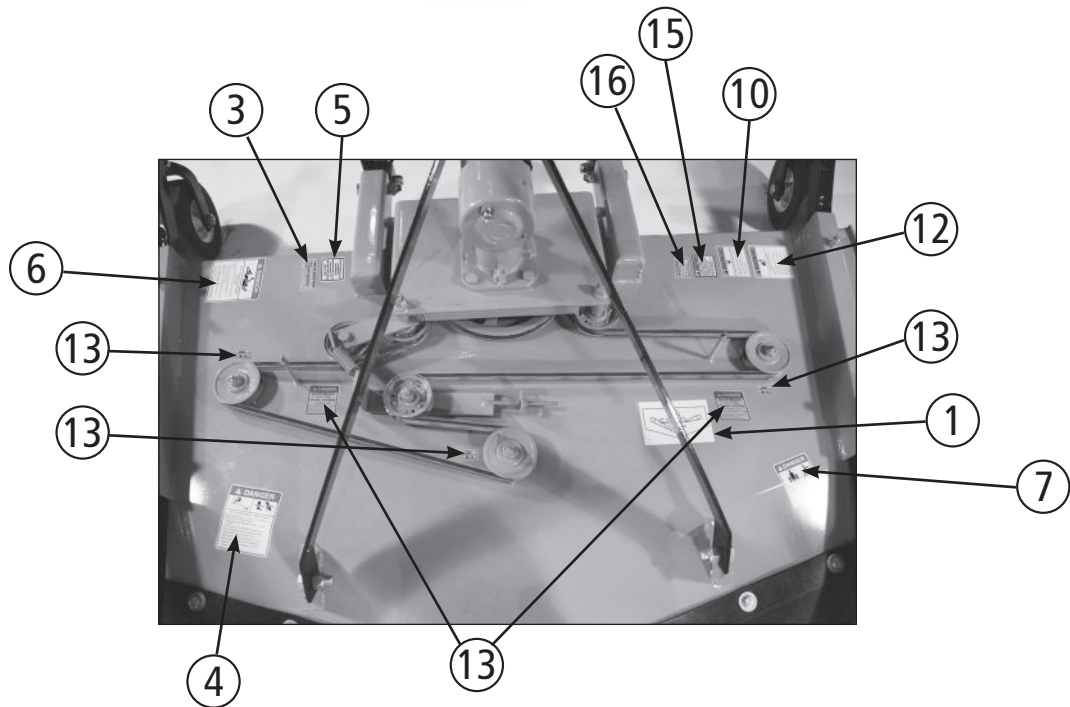
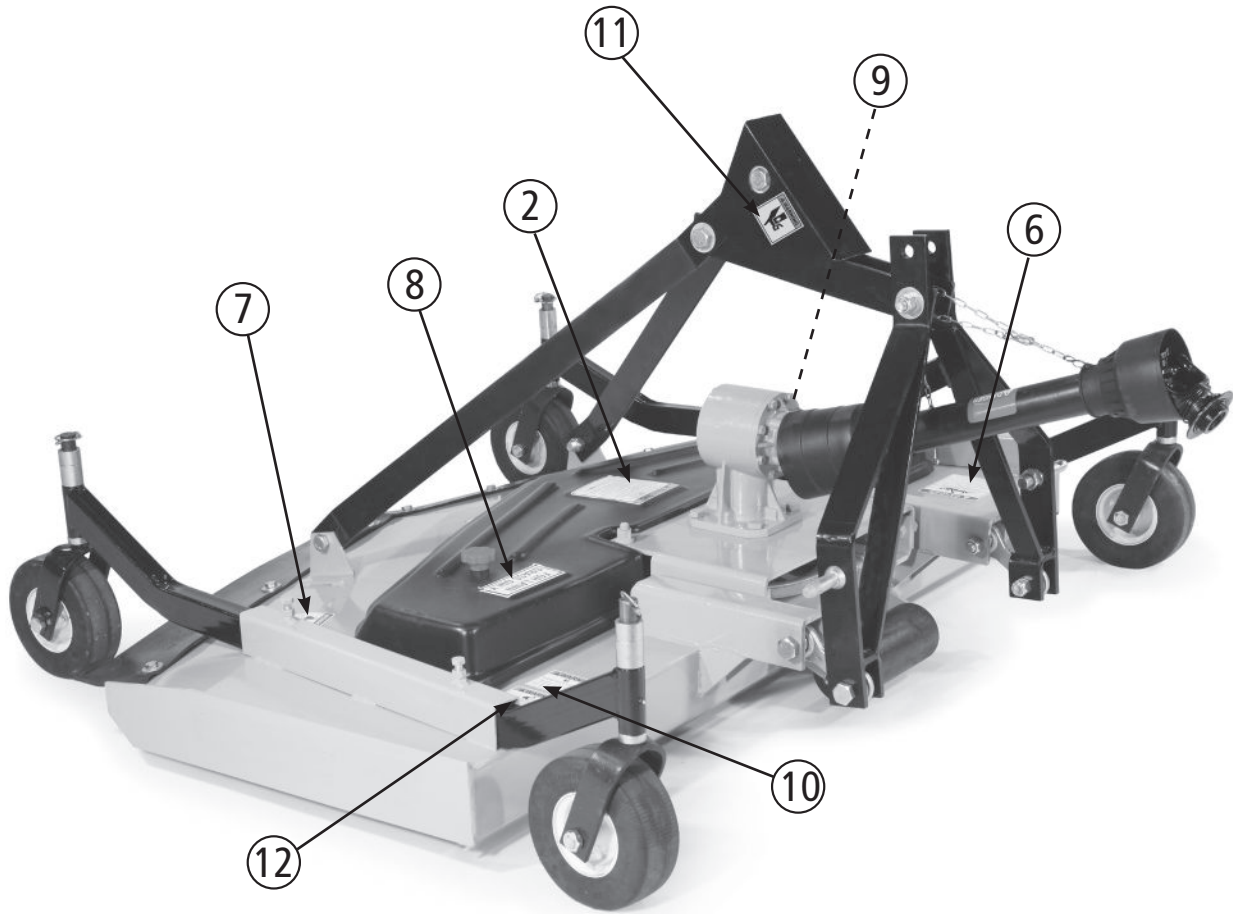





ATTENTION! BECOME ALERT! YOUR SAFETY IS INVOLVED!

Replace Immediately if Damaged!

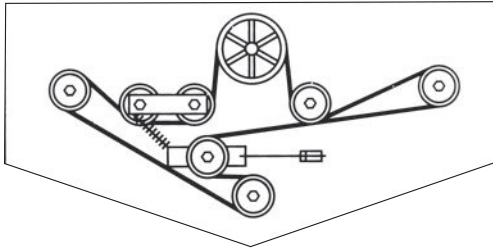

① **DRIVE BELT**



② **PREVENT INJURY**



③ **ROTATING BLADES**



⑤ **ROTATING BLADES**



④ **ROTATING BLADES**



⑧ **GRASS ONLY**



⑦ **THROWN OBJECT**

⑨ **NO GREASE**

⑥ **ROTATING DRIVELINE**

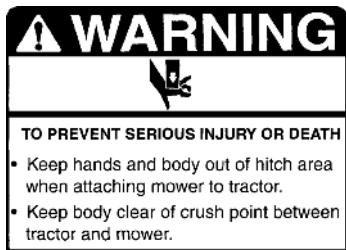

⑩ **CRUSH POINT**



⑪ **CRUSH POINT**



⑫ **MOVING PARTS**

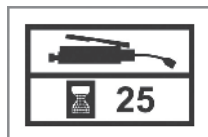

⑬ **GREASE POINTS**



⑮ **NEEDS OIL**

⑭ **GUARD SAFETY**



⑯ **540 RPM**

# DESCRIPTION

Your Finish Mower has been carefully designed for cutting grass. This manual is provided to give you the necessary operation and maintenance instructions for keeping your finish mower in excellent operating condition. Please read this manual thoroughly. Understand the purpose of the controls and how to use them. Observe all safety precautions on the machine and as noted throughout this manual.

## Major components

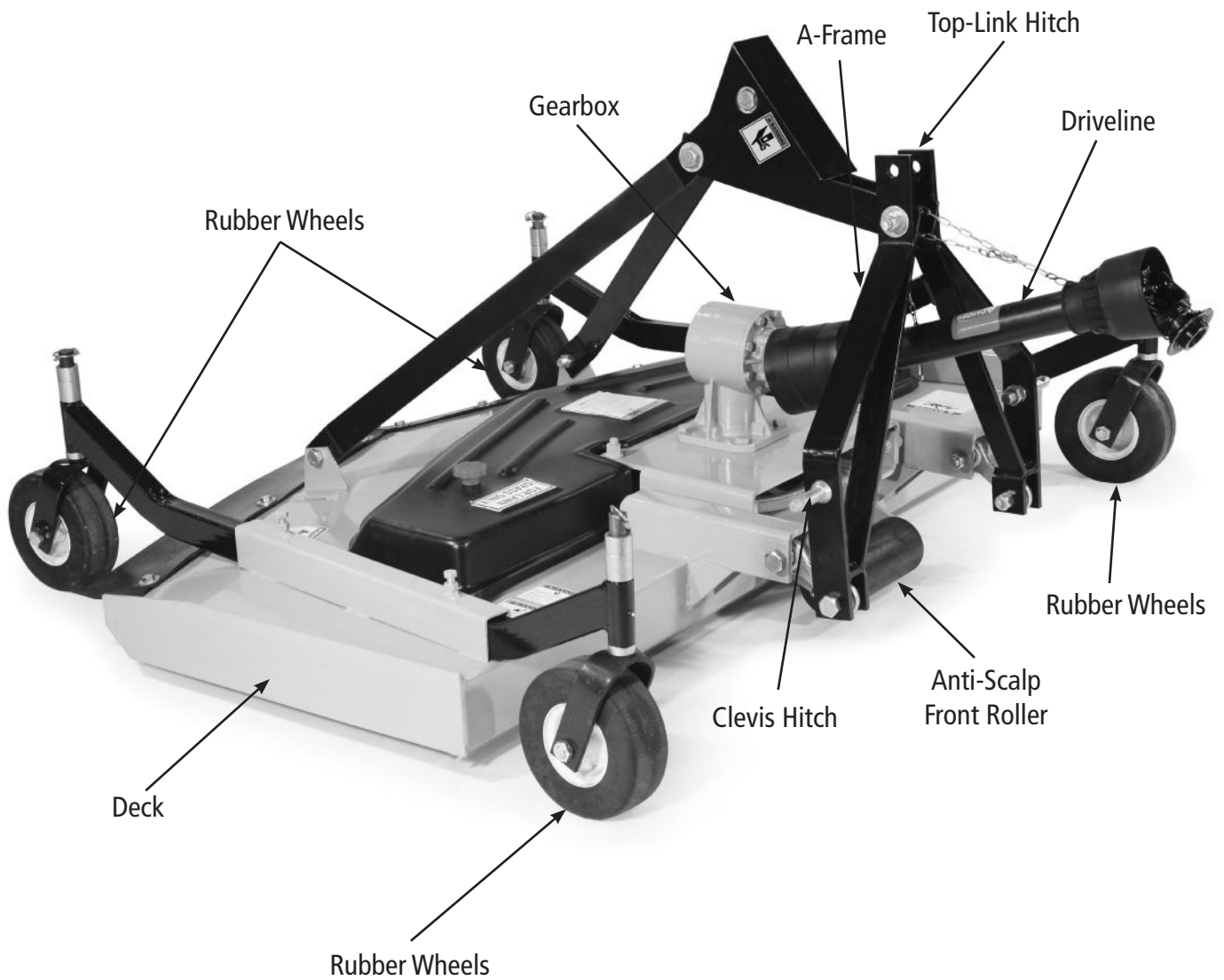

Model	5 foot	6 foot	7 foot
<b>Capacity</b>			
Cutting Width, in.	60	72	84
Cutting Height, in. .5" increments	.75-5.25	.75-5.25	.75-5.25
<b>Tractor Compatibility</b>			
Tractor PTO HP Range	20-60	20-60	20-60
Tractor PTO	540	540	540
<b>Hitch</b>			
Category	Cat. 1	Cat. 1	Cat. 1
Lower Hitch	Clevis w/Plated Pins	Clevis w/Plated Pins	Clevis w/Plated Pins
Top Link	Clevis	Clevis	Clevis
Quick-Hitch Compatible	Yes	Yes	Yes
<b>Dimensions</b>			
Overall Width, in.	63	75	87
Overall Length, in.	70.75	73.25	75.75
Overall Height, in.	34.25	34.25	34.25
Approx. Weight, lb.	628	670	712
Deck Thickness, gauge	.1875	.1875	.1875
<b>Driveline</b>			
PTO Drive Shaft ASM.	Heavy-Duty w/quick coupler, ASAE Cat. 2	Heavy-Duty w/quick coupler, ASAE Cat. 2	Heavy-Duty w/quick coupler, ASAE Cat. 2
<b>Gearbox</b>			
HP Rating	30	30	30
<b>Blades</b>			
Thickness, in.	.25	.25	.3125
Width, in.	2.5	2.5	2.5
Type	Heat Treated Alloy Steel	Heat Treated Alloy Steel	Heat Treated Alloy Steel
Blade Tip Speed, ft./min.	18,237	18,173	17,248
Blade Options	Standard Blades: Medium Lift Optional Blades: High Lift	Standard Blades: Medium Lift Optional Blades: High Lift	Standard Blades: Medium Lift Optional Blades: High Lift
Blade Overlap, in.	1.25	1.25	1.25
Blade Spindles, in.	1.375 dia., Cast Iron Greaseable Hubs	1.375 dia., Cast Iron Greaseable Hubs	1.375 dia., Cast Iron Greaseable Hubs
Discharge	Rear	Rear	Rear
<b>Wheels</b>			
Type	Castered Gauge	Castered Gauge	Castered Gauge
Diameter, in.	10	10	10
Width, in.	3.25	3.25	3.25
Caster Wheel Spindle, in.	1 Diameter with Nylon Bushing	1 Diameter with Nylon Bushing	1 Diameter with Nylon Bushing
Front Roller	Optional	Optional	Optional

# PREPARATION

## SELECTING TRACTOR PTO SPEED

**IMPORTANT:** Never operate a mower equipped for 540 rpm PTO drive with a tractor equipped to 1000 rpm PTO.

**Always run tractor at rated PTO speed.  
Overspeed will cause damage to drive system.**

Refer to your tractor Operator's Manual to change PTO stub shaft, if necessary.

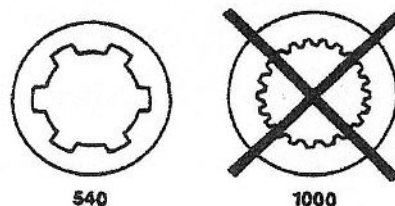

## POSITIONING DRAWBAR

**IMPORTANT:** To prevent damage to the driveline, remove, shorten, or place drawbar to one side. If equipped with clevis, remove it.

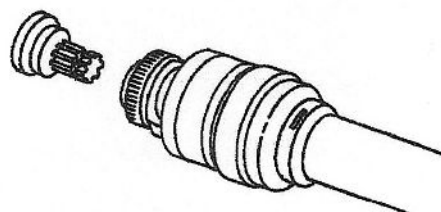

## PREPARING THE MOWER

Perform the following procedures before operating the mower:

### Gearbox

- Check oil level. (See Lubrication and Maintenance section.)
- Check hardware torque. (See Lubrication and Maintenance section.)
- Remove any material wound on gearbox shafts.
- Check oil seals for leakage.

### Blades and Blade Holder

- Inspect blades for wear or damage. (See SERVICE MOWING BLADES in Operation section.)
- Check blade hardware torque. (See Lubrication and Maintenance section.)
- Check blade holder hardware torque. (See Lubrication and Maintenance section.)

### Hitch Pins

- Insure all bolts on mower are fastened securely.
- Hardware on the lower clevises need to be snug, but do not over tighten because the clevises need to pivot as the mower hitch floats.

### Lubricating the Mower

- Lubricate mower and driveline. (See Lubrication and Maintenance section.)

## CHECKING DRIVELINE SHIELDS



**Entanglement in rotating driveline can cause serious injury or death. Disengage PTO, engage parking brake or place transmission in "PARK", shut off tractor, and remove key before working near driveline.**

Check driveline shields by making sure they rotate freely.

Lubricate or repair if necessary.

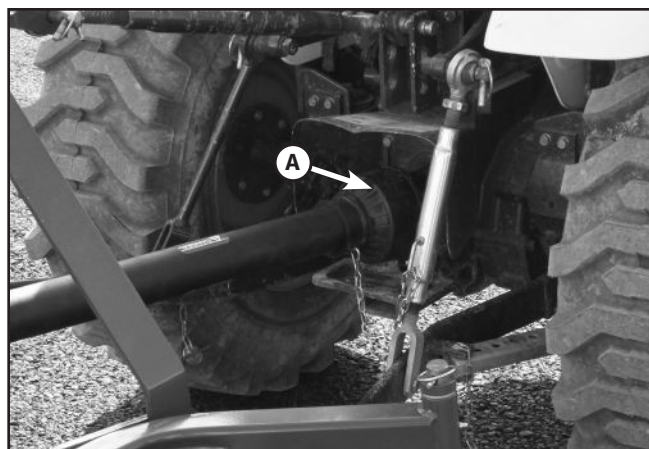

A - Driveline Shield

## ASSEMBLY AND SETUP

1. With finish mower still in crate, lay flat on a level surface. Remove the top and side sections of the crate, leaving the finish mower resting on the bottom section. Set aside PTO shaft.

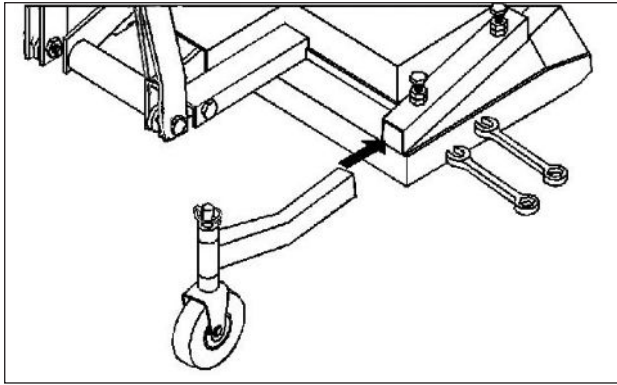

2. Insert tailwheel arms as shown and tighten both the bolt and jam nut.

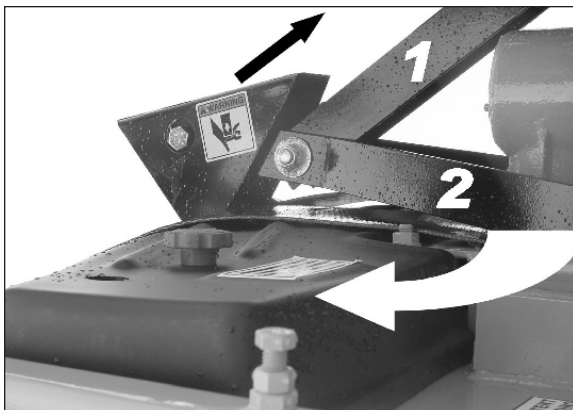
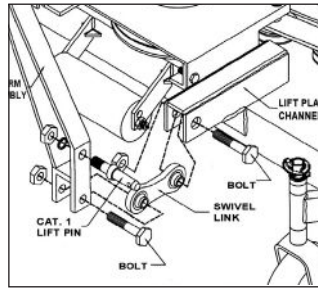
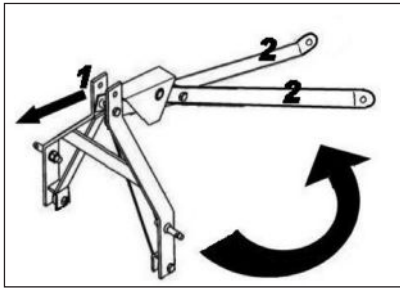

3. Raise A-Frame assembly (#1) forward and swivel brace arms (#2) around toward rear of the mower.



4. Hook the brace arms to the tabs (#3) on the back of the mower with the bolts provided.

5. Fully tighten all nuts and bolts.



6. Your mower is now set up. See next page for servicing the mower before using.

(continued on next page)

# ASSEMBLY AND SETUP

(continued from previous page)

## BEFORE PUTTING MOWER INTO SERVICE

**IMPORTANT: This mower was shipped without oil in gearboxes and without grease in grease fittings. UNIT MUST BE SERVICED BEFORE USING.**

*NOTE: Fill gearbox using gear oil (type GL5-85W 140 or Triple Zero Grease; which can be poured, and has "EP" i.e. "Extreme Pressure" additives).*

*NOTE: For all grease fittings use TYPE/grade II tube grease.*

1. Place finish mower so that the deck is secure and level.
2. Using 7/8" wrench, remove 1/2" vented pipe plug located at the top of gearbox.
3. Remove check plug located at the lower 1/3 of gearbox.
4. Fill gearbox on top using gear oil until oil begins to overflow from check plug hole in front of gearbox.



**DO NOT overfill gearbox. This could cause damage to oil seals and can cause permanent damage to the gearbox. This issue will not be covered under warranty.**

5. Replace and tighten the check plug.
6. Replace and tighten the 1/2" vented pipe plug and clean away any excess oil.
7. Grease the fitting on all four tailwheel support bars.
8. Grease the two (2) grease fittings on the PTO universal joints.
9. Grease the two (2) grease fittings on the PTO safety shield.
10. Separate the PTO shaft and grease the inner surface.

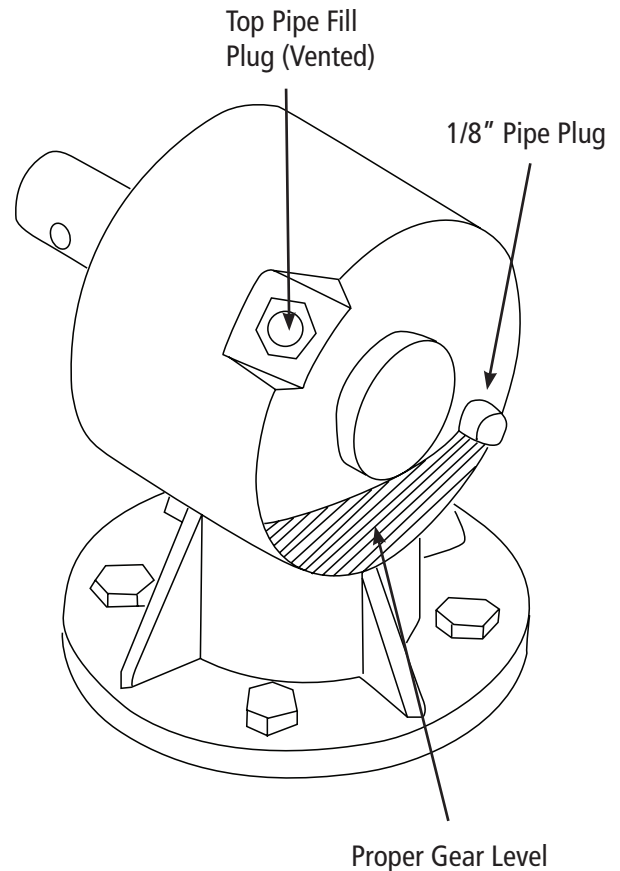

## Final Inspection and Adjustments

**IMPORTANT: PTO driveline may be too long for some tractor models, causing tractor transaxle damage. Modify driveline if necessary.**

Attach finish mower to tractor and check mower-to-tractor driveline telescoping length clearance.

(See CHECKING DRIVELINE/MOWER CLEARANCE in Attaching section.)

**IMPORTANT: Blade hardware MUST be checked after the first hour and every eight (8) hours thereafter.**

Check blade hardware torque. Re-tighten hardware after one hour of operation and every eight (8) hours thereafter.

(See MAINTENANCE BEFORE EACH USE in Lubrication and Maintenance section.)

### MODIFY PTO DRIVELINE (IF NECESSARY)

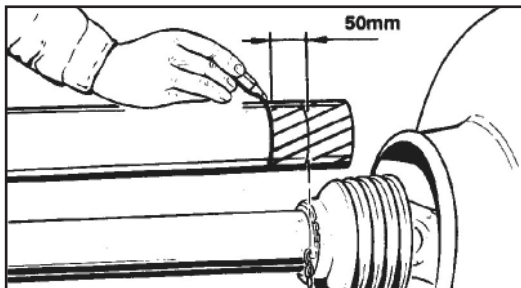

1. To adjust the length, hold the half-shafts next to each other in the shortest working position and mark them.



4. Round off all sharp edges and remove burrs. Grease sliding profiles. No other changes may be made to PTO drive shaft and guard.

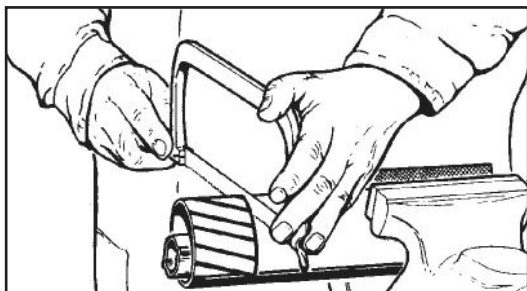

2. Shorten inner and outer guard tubes equally.

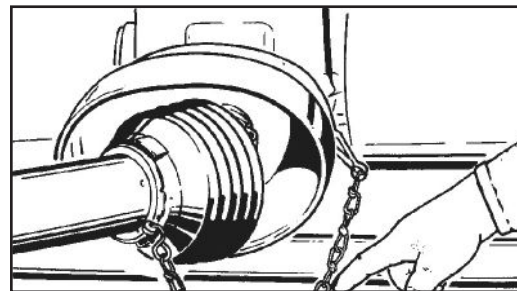

5. Chains must be fitted so as to allow sufficient articulation of the shaft in all working positions.

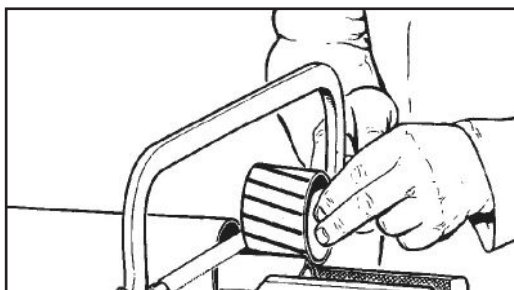

3. Shorten inner and outer sliding profiles by the same length as the guard tubes.

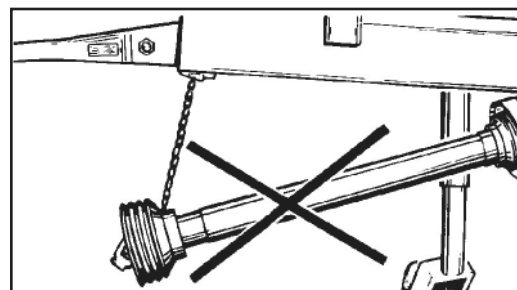

6. The PTO drive shaft must not be suspended from the chains!

# ATTACHING

## ATTACHING MOWER TO TRACTOR WITH THREE-POINT HITCH



**To avoid bodily injury or machine damage whenever an implement is attached, put transmission in PARK position and check the full range of hitch for interference, binding, or PTO separation. Do not stand between tractor and implement.**

1. Back up tractor to mower with hitch points approximately in alignment.
2. Engage tractor parking brake and/or place transmission in "Park".
3. Shut off tractor engine and remove key.
4. Remove hitch pins from center link loop and lower hitch clevises.
5. Align tractor draft arms with lower hitch clevises and install pins.
6. Align center link with upper hole in mower mast loop and install center link mounting hardware.



**Shut off tractor engine before attaching PTO driveline. Entanglement in rotating driveline can cause serious injury or death.**

**IMPORTANT: Keep driveline and powershaft splines clean of paint, dirt and chaff. Apply grease to tractor PTO shaft before attaching PTO driveline.**

7. Shut off tractor engine.
8. Raise tractor PTO shield, if equipped.

**IMPORTANT: Do not use shielding bell on driveline to lift driveline into position. Damage to shielding can occur.**

9. Support driveline, cradling it in your hand.
10. Press pin/slide collar and align splines by rotating mower driveline. Push driveline onto tractor PTO shaft until collar snaps into place.
11. Pull back on shield to make sure driveline is locked.
12. Do not pull back on collar, this will release latch.
13. Lower tractor PTO shield, if equipped.

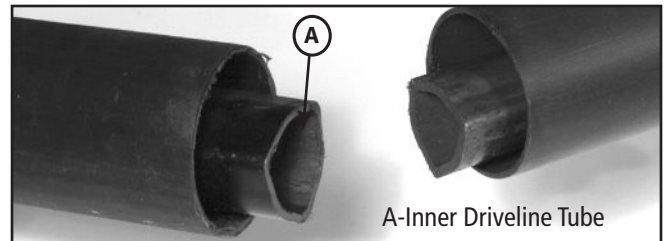

*NOTE: If more clearance is desired to hookup PTO driveline or to create proper clearance from tractor tires, adjust the lower hitch. See below.*

Adjust lower hitch by loosening bolts with a 15/16" wrench. Retighten hardware to a snug position but not tight as the lower hitch clevises need to be able to pivot as the hitch floats.

*NOTE: Replace the flanged lock nuts if the bolts do not stay snug.*



## CHECKING DRIVELINE/MOWER CLEARANCE

**IMPORTANT: Prevent driveline damage from contact with frame or machine damage from contact with tractor tires. Raise mower slowly and check for interference. If necessary, shorten center link or lengthen lift links to provide clearance to full lift height.**

1. Raise mower slowly and check for clearance between driveline shield and mower deck.
2. Check clearance between tractor tires and foot guards or chain deflector.
3. Check to see if hitch height position will provide clearance desired.

*NOTE: Final adjustments should be made before operating mower. See CUTTING HEIGHT ADJUSTMENT in the Operation section. Center link should be installed in lowest hole at tractor end if there are multiple holes. Lift height may also be limited by installing stops on rockshaft control lever bracket.*

4. Shorten center link or lengthen lift links to provide clearance. (See your tractor Operator's Manual.)

**IMPORTANT: PTO driveline may be too long for some tractor models, causing tractor transaxle damage. Hold driveline sections parallel to each other and check for a minimum of 6 inches overlap.**

5. Raise and lower mower slowly to check for binding or interference. Check mower-to-tractor driveline telescoping length to ensure it does not bottom out. Modify driveline if necessary. (See MODIFYING PTO DRIVELINE in Assembly section.)

## DETACHING MOWER FROM TRACTOR



### CAUTION

**To prevent personal injury caused by unexpected movement:**

- a. Park machine on a level surface.
- b. Engage tractor parking brake and/or place transmission in "Park".
- c. Disengage PTO.
- d. Shut off tractor engine and remove key.

1. Park mower on a level surface, or block tailwheel so machine cannot roll after detaching from the tractor.
2. Slowly push hitch control lever to lower mower close to the ground.
3. Engage tractor parking brake and/or place transmission in "Park".



### DANGER

**Shut off tractor engine before detaching PTO driveline. Entanglement in rotating driveline can cause serious injury or death.**

4. Shut off tractor engine and remove key.
5. Raise tractor PTO shield, if equipped.



**IMPORTANT: Do not use plastic shield on driveline to hold driveline in position. Damage to shielding can occur.**



6. Press push pin or pull collar back toward mower and slide driveline off tractor shaft.
7. Support and collapse driveline completely and lower onto PTO holder or onto mower deck.
8. Lower tractor PTO shield, if equipped.
9. Block the mower wheels, remove hitch pins and drive away.

## General Safety

Only qualified people should operate this machine. Wear close fitting clothing and safety equipment appropriate to the job. It is recommended that tractor be equipped with Rollover Protective Systems (ROPS) and a seat belt be used. Before beginning operation, clear work area of objects that may be picked up and thrown. Check for ditches, stumps, holes or other obstacles that could upset tractor or damage finish mower. Always turn off tractor engine, set parking brake, and allow finish mower blades to come to a complete stop before dismounting tractor.

### PREPARING MOWER FOR OPERATION



**To help prevent severe injury or death to you or someone else:**

- a. Do not engage tractor PTO when mower is in fully raised position transport position).**
- b. Keep all persons away from machine when raising and lowering mower.**

**IMPORTANT: To avoid damaging the machine from impact on ground when lowering, adjust rate at which hitch will lower.**

1. Adjust tractor rockshaft rate-of-drop. Allow at least two seconds for machine to lower from full lift height to the ground. (See your tractor Operator's Manual.)
2. If equipped, disengage tractor hitch/rockshaft control lever from transport lock position and lower mower to the ground. (See your tractor Operator's Manual.)
3. Adjust tractor lift links to level machine side-to-side. (See your tractor Operator's Manual.)
4. Adjust cutting height and angle. (See Adjusting Cutting Height and Angle in this section.)

### LEVELING THE MOWER

**IMPORTANT: Tractor and mower should be on level ground.**

1. Set lower hitches and upper floating hitch.
2. Start tractor and raise mower, watch that tractor draw bar (if not removed) does not interfere with mower.
3. Slowly lower the mower until gauge wheels touch the ground and lower mower 3-point hitch bars are parallel to the ground in floating position. Set tractor 3-point stop.
4. Set park brake and turn off tractor. Remove key from ignition.
5. Rotate blades parallel to direction of travel.
6. Measure the clearance from the cutting edge to the ground at front and rear of the blade. This measurement should be equal or have the blade at the front of the mower not more than 1/2" lower than the blade at the rear of the mower.

(continued on next page)

## CUTTING HEIGHT ADJUSTMENT



Help prevent bodily injury or death caused by entanglement in rotating driveline or blades. Entanglement in rotating driveline or being struck by blades can cause serious injury or death. Before making any adjustments:



- a. Lower machine until rear wheel just touches or is slightly above ground.
- b. Engage tractor parking brake and/or place transmission in "PARK".
- c. Disengage PTO.
- d. Shut off tractor engine and remove key.
- e. Wait until all moving parts have stopped.
- f. Disconnect PTO driveline from tractor.

1. Raise finish mower off the ground with the tractor and SECURELY BLOCK INTO POSITION.
2. Remove pin from top of wheel fork assembly. Lower wheel for assembly from tail wheel arm.
3. Arrange spacers until desired cutting height is achieved. Cutting heights range approximately 2.0 - 6.0 inches in height.
4. Reinstall wheel fork assembly into tail wheel arm and install keeper pin.
5. Repeat adjustment process on remaining wheel for assemblies. NOTE: Make sure all are adjusted to the same height for an even cut.

## BELT TENSION



Belt drive system under spring tension; use care to avoid bodily harm!

1. Remove top cover.
2. Release adjustment spring.
3. Loosen nut on adjustment pulley to allow for movement.
4. Loosen nut on left side of "L" bracket and nut on adjustment pulley.
5. Turn nut on left side of "L" bracket in counter clockwise direction until belt is tight.
6. Re-tighten nut on right side of "L" bracket and nut on adjustment pulley.
7. Re-hook adjustment spring.



Excessive tension on the belt may lead to premature failure of belt and drive components. Excessive tension on the belt may also lead to a safety hazard to the operator or bystander.

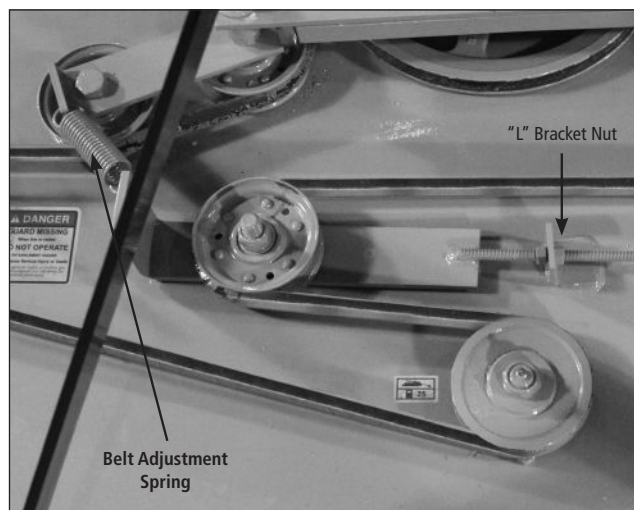

# OPERATION

## SERVICE MOWING BLADES

### Blade Inspection

**Blade Wear:** As blades wear and are sharpened, the blade performance will be reduced.

**Bent, Deformed or Split Blades:** Should be removed from unit and discarded. DO NOT attempt to straighten for reuse.



**DO NOT attempt to modify blade, such as hard surfacing, heat or cold treating and/or by any other method.**



**DO NOT try to straighten a blade that is bent. Never weld a broken or cracked blade. ALWAYS replace with a new blade to assure safety.**

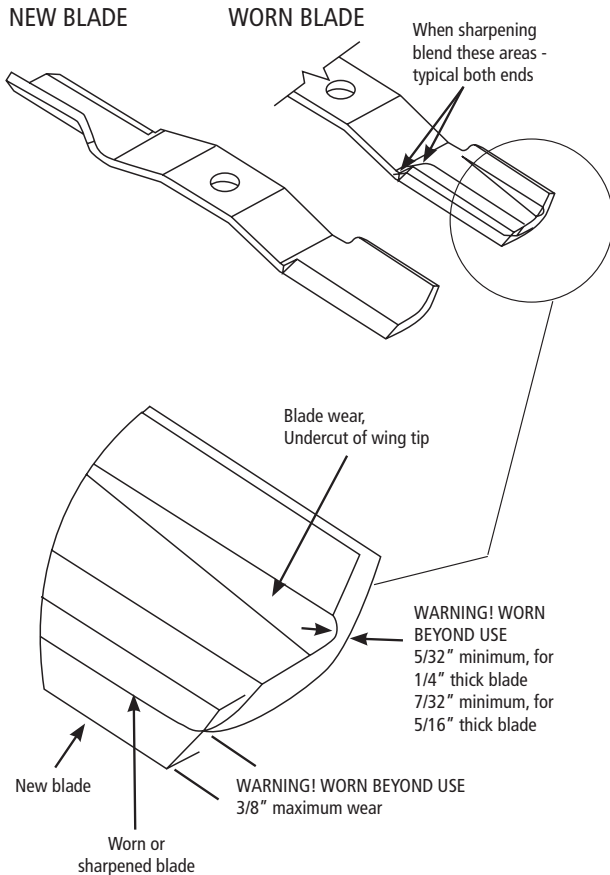

**IMPORTANT: Operating with blades that are not alike will cause vibration. Always replace worn or broken blades in pairs. Never replace a single blade. Check blades regularly for wear or breakage.**

## V-BELT INSTALLATION

These illustrations are also on the labels located on top of mower decks.

1. Remove top cover.
2. Release adjustment spring.
3. Loosen nut on adjustment pulley to allow for movement.
4. Loosen nut on right side of "L" bracket.
5. Loosen belt by moving adjustment pulley in opposite direction you would tighten belt.
6. Remove nuts (2) from hinged gearbox plate from finishing mower deck.
7. Loosen nuts (2) from hinged bolt gearbox plate.
8. Raise gearbox assembly and slip out belt.
9. See below for belt replacement on pulleys.
10. Do step 5 thru 7 under Section: "BELT TENSION" to tighten.

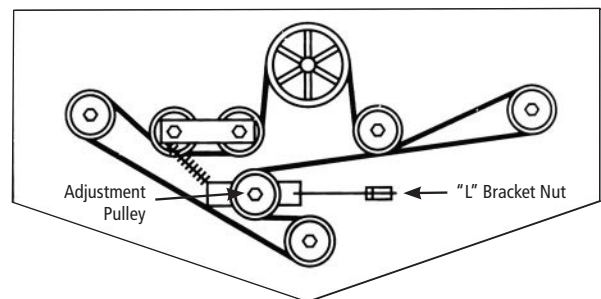
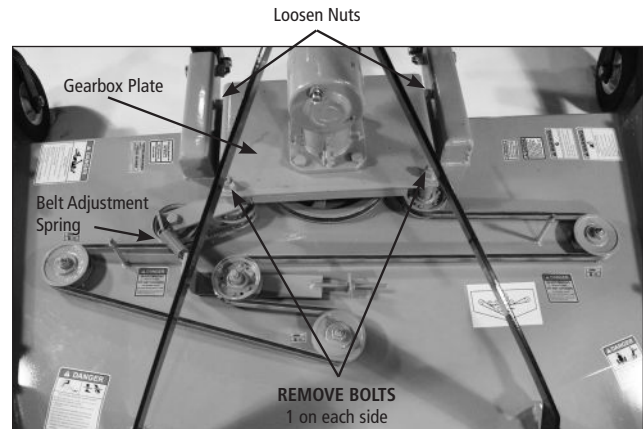

**KEEP RIDERS OFF MACHINE**

**Keep riders off. Riders are subject to injury or death such as being struck by foreign objects and being thrown off the machine. Riders may also fall off and be run over by machine. Riders also obstruct the operator's view resulting in the machine being operated in an unsafe manner.**



**To help prevent severe injury or death to you or someone else:**

**Never operate mower when other people are in the vicinity. Debris can be thrown hundreds of feet. Keep all deflectors in place. Including those on discharge opening at front and rear of deck. Before starting machine, lower to the ground. Engage tractor PTO and gradually increase the speed.**

**Operate tractor at rated PTO speed. If engine speed is too slow or too fast, machine may not perform properly.**

**Where conditions make it necessary to slow ground speed, shift to a lower gear rather than reducing engine speed. The engine will maintain rated speed and keep mower running at optimum cutting speed.**

**Operate machine from tractor seat only. Never adjust machine while in motion.**

**Slow down when turning or traveling over rough ground.**

**Avoid holes when operating on hillsides. Tractor roll-over could result.**

**Shut off tractor engine and engage tractor parking brake and/or place transmission in "Park" when leaving tractor. Remove key when leaving tractor unattended.**

**Components behind shields may rotate several minutes after power is shut off. Look and listen for evidence of rotation before removing shielding.**

**FOLLOW SAFE OPERATING PROCEDURES**

1. Perform BEFORE EACH USE maintenance in the Lubrication and Maintenance section.
2. Start tractor per tractor operator's manual.
3. Raise/lower 3-point hitch to place mower in working position.
4. Look to be sure no one is near mower.
5. With tractor at idle speed, slowly engage PTO drive.



**Stay clear of rotating driveline. Do not operate without driveline shields in place and in good condition. Failure to heed these warnings may result in personal injury or death.**

6. Set tractor throttle for appropriate PTO speed (540RPM).



**Rotating mower blades. Stand clear until all motion has stopped. To avoid an accidental fall from tractor and possible injury by mower, it is recommended that tractor be equipped with rollover protective system (ROPS) and a seatbelt be used by the operator for all mowing operations.**

7. Place tractor in gear and proceed forward.

*NOTE: Tractor forward speed should be controlled by gear selection, not engine speed. For maximum cutting efficiency, forward speed should allow mower to maintain a constant, maximum blade speed. If mower stalls or tractor engine bogs, disengage PTO. Before re-engaging PTO, position mower in a cut area and reduce tractor throttle to idle. If finish mower continuously stalls, select lower gear and/or increase cutting height.*

# LUBRICATION AND MAINTENANCE

## LUBRICATING AND MAINTAINING MACHINE SAFELY



**Help prevent bodily injury or death caused by entanglement in rotating driveline or blades. Entanglement in rotating driveline or being struck by blades can cause serious injury or death.**

**Components will be hot after operation. Let all components cool before servicing.**

**Replace all shields after lubricating or servicing.**

## MAINTENANCE CHECK LIST

Perform scheduled maintenance as outlined below. Lower machine to ground, turn off tractor and set parking brake before doing maintenance inspections or work. All bolts should be torqued as recommended in the Torque Specifications unless otherwise indicated.

## MAINTENANCE BEFORE EACH USE



**Do not clean, lubricate, or adjust machine while it is in motion.**

1. Check tractor tire air pressure. Refer to tractor operator's manual.
2. Check blades and spindles to be sure that no foreign objects such as wire or steel strapping bands are wrapped around them.
3. Check blade bolts for tightness. Locate blade hardware under hole in deck behind gear box.  
(Tighten to 425 ft./lbs.)

**IMPORTANT: Operating with loose blade hardware will damage the blade holder and blades.**

4. Inspect blades for wear. (See SERVICING MOWING BLADES in operation section). Always replace all blades and bolts on blade holder at the same time.
5. Make certain driveline shields are in place and in good repair.
6. Inspect wheels for wear, damage, or foreign objects. (Repair or replace if necessary.)
7. Before each use refer to LUBRICATION BEFORE EACH USE in this section.
8. During operation, listen for abnormal sounds which might indicate loose part, damaged bearings, or other damage.

## MAINTENANCE AFTER EACH USE

1. Clean all debris from finish mower especially under side of deck. When cleaning underside of deck, securely block machine into position.

**IMPORTANT: To help prevent structural damage caused by loose hardware, check all hardware after first eight (8) hrs of use and tighten all hardware to specifications.**

## OBSERVE LUBRICATION SYMBOLS

Lubricate with multipurpose grease.



(continued on next page)

(continued from previous page)

## LUBRICATION BEFORE EACH USE

### 1. Driveline Universal Joints

- a. Apply multi-purpose grease with a grease gun.

### 2. Driveline Guard

- b. Apply 2-3 shots of multipurpose grease with grease gun to plastic fitting.

### 3. Driveline Profile

- c. Disconnect PTO Driveline.
- d. Pull two sections apart.
- e. Apply thin coat of multi-purpose grease to inside of female section.
- f. Re-assemble sections.

*NOTE: Pull each section to be sure driveline and shields are securely connected. Make certain PTO shielding is in good condition. Do not grease outer or inner plastic shields.*

### 4. Wheel Pivot Tube

- g. Apply multi-purpose grease with grease gun.

### 5. Wheel

- h. Apply multi-purpose grease with grease gun.

### 6. Gearbox

- i. Check oil level by removing oil level check plug on side of gearbox.
- j. Add 90W gear oil if necessary to bring oil level to check plug hole.

### 7. Belt Drive

- k. Apply multi-purpose grease with grease gun.

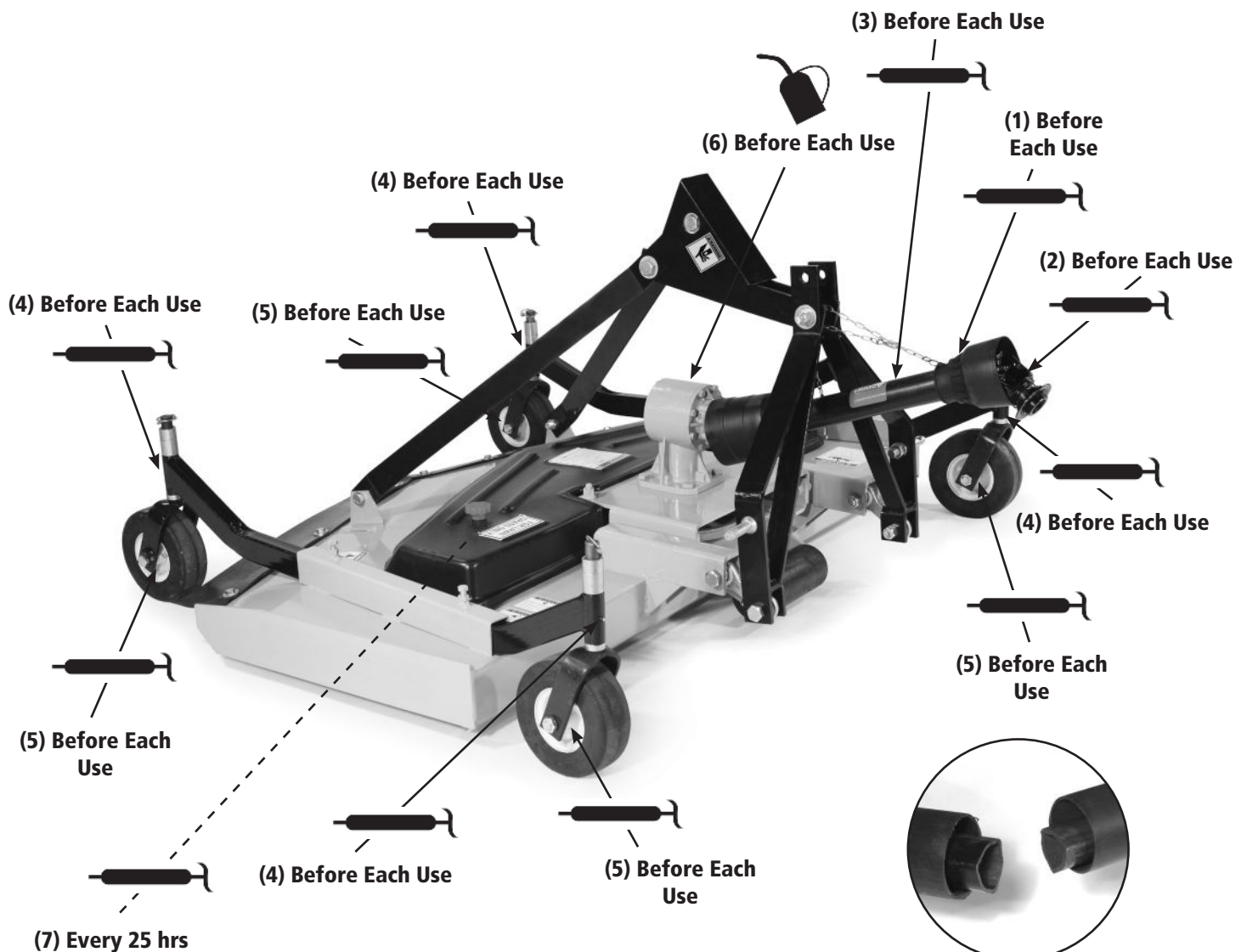

3d. Pull two sections apart.

## PRACTICE SAFE SERVICE PROCEDURES

  
**CAUTION** To help prevent personal injury caused by unexpected movement, be sure to service machine on a level surface.

Before servicing or adjusting machine connected to a tractor:

1. Lower machine to the ground.
2. Engage tractor parking brake and/or place transmission in "Park".
3. Disengage PTO.
4. Shut off tractor engine and remove key.
5. Wait until all moving parts have stopped.
6. Disconnect PTO driveline from tractor.

The blades and blade pan may rotate for several minutes after PTO is shut off. Look and listen for rotating driveline to stop before working on the mower.

When servicing blades or blade pan, it will be necessary to work underneath mower. Be sure to support mower frame at all four corner locations with safety shop stands to prevent accidental lowering. Do not position safety stands under wheel support because these components can rotate.

## DISASSEMBLING DRIVELINE SHIELD

1. Unhook driveline safety chain from one end of driveline.

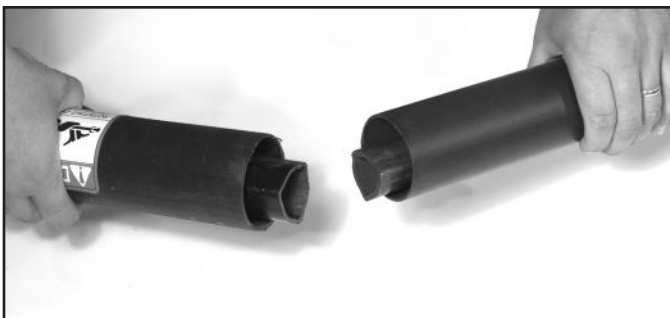

2. Separate driveline into two (2) pieces.

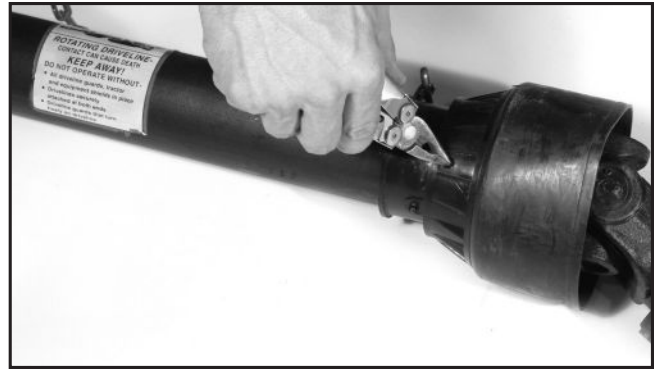

3. Using pliers, screwdriver or punch, depress white tabs in each of the release holes around the driveline shield. Driveline tab should "snap" somewhat when firmly depressed.

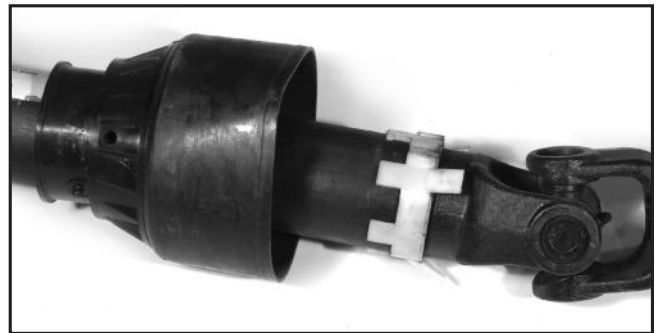

4. Slide shield collar back.

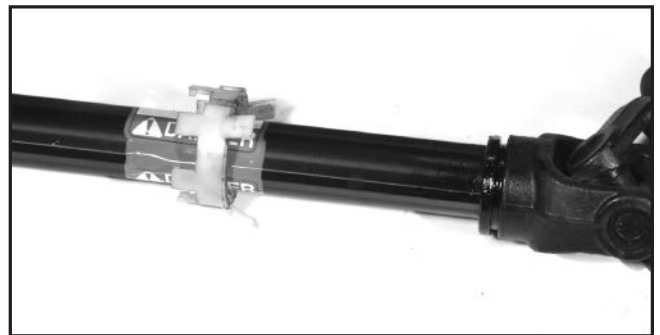

5. If needed, separate white tab collar and slide shield tube back.

  
**CAUTION** DO NOT operate PTO shaft without shielding installed.

(continued on next page)



(continued from previous page)

## RE-ASSEMBLING DRIVELINE SHIELD

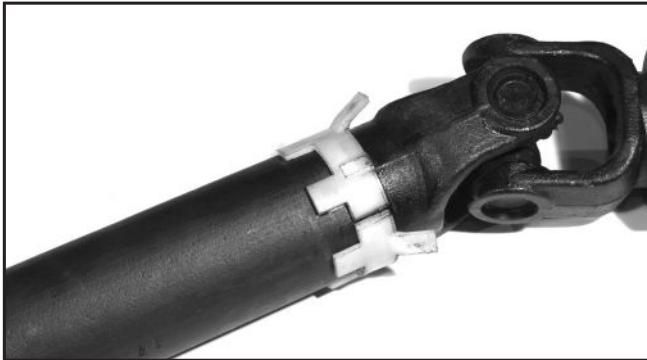

1. Replace white tabbed collar in groove of PTO shaft.



2. Slide driveline shield tube over white tab collar. Align slots/holes with holes in tube.

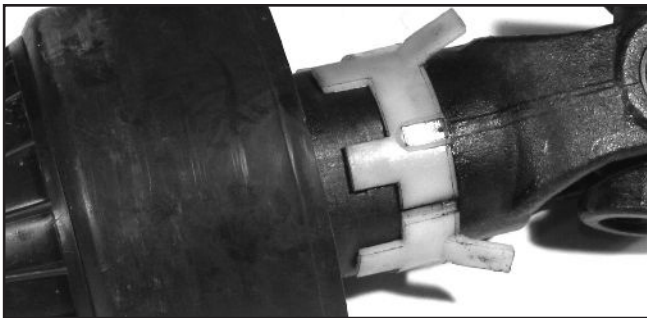

3. Slide universal joint cover up tube toward universal joint. Align grease fitting on shield with white square tabs on collars. This will properly align the position notch and all three (3) tabs.

4. Slide collar shield into place until locked.

## AT THE END OF YOUR CUTTING SEASON

1. Drain and change the oil in the gearbox.
2. Check (and replace where necessary) blades, bolts, and nuts on the mower.
3. Clean mower and touch up any rust spots that may have appeared.
4. Replace any safety decals if damaged.
5. Store finish mower in a clean dry location.



**Always use a tractor to position equipment for storage. Never attempt to move equipment by hand.**

# TROUBLESHOOTING GUIDE

<b>Problem</b>	<b>Possible Remedy</b>
<b>Rear discharge area plugged</b>	<ol style="list-style-type: none"> <li>1. Check installation of belt.</li> <li>2. Wait until grass dries.</li> <li>3. Raise cutting height of mower and cut grass twice.</li> <li>4. Mow at full throttle (540 PTO rpm), check PTO speed and tractor engine.</li> <li>5. Shift transmission to lower gear.</li> </ol>
<b>Belt slipping</b>	<ol style="list-style-type: none"> <li>1. Unplug and clean mower deck.</li> <li>2. Remove belt guard shields and clean sheaves.</li> <li>3. Tighten spring take-up eyebolt.</li> <li>4. Replace belt.</li> <li>5. Shift transmission to lower gear.</li> </ol>
<b>Excessive vibration</b>	<ol style="list-style-type: none"> <li>1. Replace blades.</li> <li>2. Replace drive belt.</li> <li>3. Replace pulleys or align.</li> <li>4. Remove belt guard shields and clean debris from belt area and sheaves.</li> <li>5. Shift transmission to lower gear.</li> </ol>
<b>Gearbox noisy</b>	<ol style="list-style-type: none"> <li>1. Check lubricant level.</li> </ol>
<b>Blades scalping grass</b>	<ol style="list-style-type: none"> <li>1. Raise cutting height by adjusting wheels.</li> <li>2. Change mowing pattern.</li> <li>3. Reduce speed turns.</li> </ol>
<b>Uneven cut</b>	<ol style="list-style-type: none"> <li>1. Shift to a lower gear.</li> <li>2. Level mower.</li> <li>3. Sharpen blades and balance or replace.</li> </ol>
<b>Tractor loaded down by mower</b>	<ol style="list-style-type: none"> <li>1. Mow at full throttle (540 PTO rpm).</li> <li>2. Shift to a lower gear.</li> <li>3. Clean mower.</li> </ol>

# TORQUE SPECIFICATIONS

## AMERICAN Bolt Head Markings

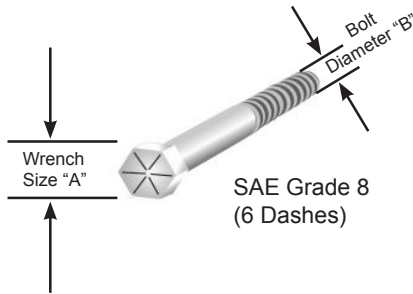

Proper torque for American fasteners used on manufactured implement.  
Recommended Torque in Foot Pounds (Newton Meters).\*

WRENCH SIZE (IN.) "A"	BOLT DIAMETER (IN.) "B" AND THREAD SIZE	SAE GRADE 2	SAE GRADE 5	SAE GRADE 8
7/16	1/4 - 20 UNC	6 (7)	8 (11)	12 (16)
7/16	1/4 - 24 UNF	6 (8)	10 (13)	14 (18)
1/2	5/16 - 18 UNC	11 (15)	17 (23)	25 (33)
1/2	5/16 - 24 UNF	13 (17)	19 (26)	27 (37)
9/16	3/8 - 16 UNC	20 (27)	31 (42)	44 (60)
9/16	3/8 - 24 UNF	23 (31)	35 (47)	49 (66)
5/8	7/16 - 14 UNC	32 (43)	49 (66)	70 (95)
5/8	7/16 - 20 UNF	36 (49)	55 (75)	78 (106)
3/4	1/2 - 13 UNC	49 (66)	76 (103)	106 (144)
3/4	1/2 - 20 UNF	55 (75)	85 (115)	120 (163)
7/8	9/16 - 12 UNC	70 (95)	109 (148)	153 (207)
7/8	9/16 - 18 UNF	79 (107)	122 (165)	172 (233)
15/16	5/8 - 11 UNC	97 (131)	150 (203)	212 (287)
15/16	5/8 - 18 UNF	110 (149)	170 (230)	240 (325)
1-1/8	3/4 - 10 UNC	144 (195)	266 (360)	376 (509)
1-1/8	3/4 - 16 UNF	192 (260)	297 (406)	420 (569)
1-5/16	7/8 - 9 UNC	166 (225)	430 (583)	606 (821)
1-5/16	7/8 - 14 UNF	184 (249)	474 (642)	668 (905)
1-1/2	1 - 8 UNC	250 (339)	644 (873)	909 (1232)
1-1/2	1 - 12 UNF	274 (371)	705 (955)	995 (1348)
1-1/2	1 - 14 UNF	280 (379)	721 (977)	1019 (1381)
1-11/16	1-1/8 - 7 UNC	354 (480)	795 (1077)	1288 (1745)
1-11/16	1-1/8 - 12 UNF	397 (538)	890 (1206)	1444 (1957)
1-7/8	1-1/4 - 7 UNC	500 (678)	1120 (1518)	1817 (2462)
1-7/8	1-1/4 - 12 UNF	553 (749)	1241 (1682)	2013 (2728)
2-1/16	1-3/8 - 6 UNC	655 (887)	1470 (1992)	2382 (3228)
2-1/16	1-3/8 - 12 UNF	746 (1011)	1672 (2266)	2712 (3675)
2-1/4	1-1/2 - 6 UNC	870 (1179)	1950 (2642)	3161 (4283)
2-1/4	1-1/2 - 12 UNF	979 (1327)	2194 (2973)	3557 (4820)

## METRIC

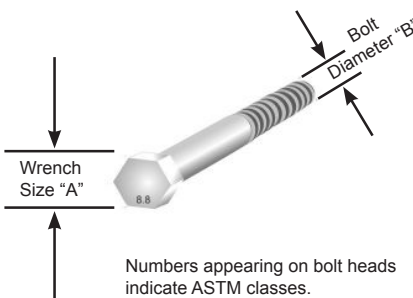

Proper torque for metric fasteners used on manufacturer implement.  
Recommended Torque in Foot Pounds (Newton Meters).\*

WRENCH SIZE (mm) "A"	BOLT DIA. (mm) "B"	ASTM 4.6	ASTM 8.8	ASTM 9.8	ASTM 10.9
8	5	1.8 (2.4)		5.1 (6.9)	6.5 (8.8)
10	6	3 (4)		8.7 (12)	11.1 (15)
13	8	7.3 (10)		21.1 (29)	27 (37)
16	10	14.5 (20)		42 (57)	53 (72)
18	12	25 (34)	74 (100)	73 (99)	93 (126)
21	14	40 (54)	118 (160)	116 (157)	148 (201)
24	16	62 (84)	167 (226)	181 (245)	230 (312)
30	20	122 (165)	325 (440)		449 (608)
33	22		443 (600)		611 (828)
36	24	211 (286)	563 (763)		778 (1054)
31	27		821 (1112)		138 (1542)
46	30	418 (566)	1119 (1516)		1547 (2096)

\*Use 75% of the specified torque value for plated fasteners. Use 85% of the specified torque values for lubricated fasteners.

# PARTS

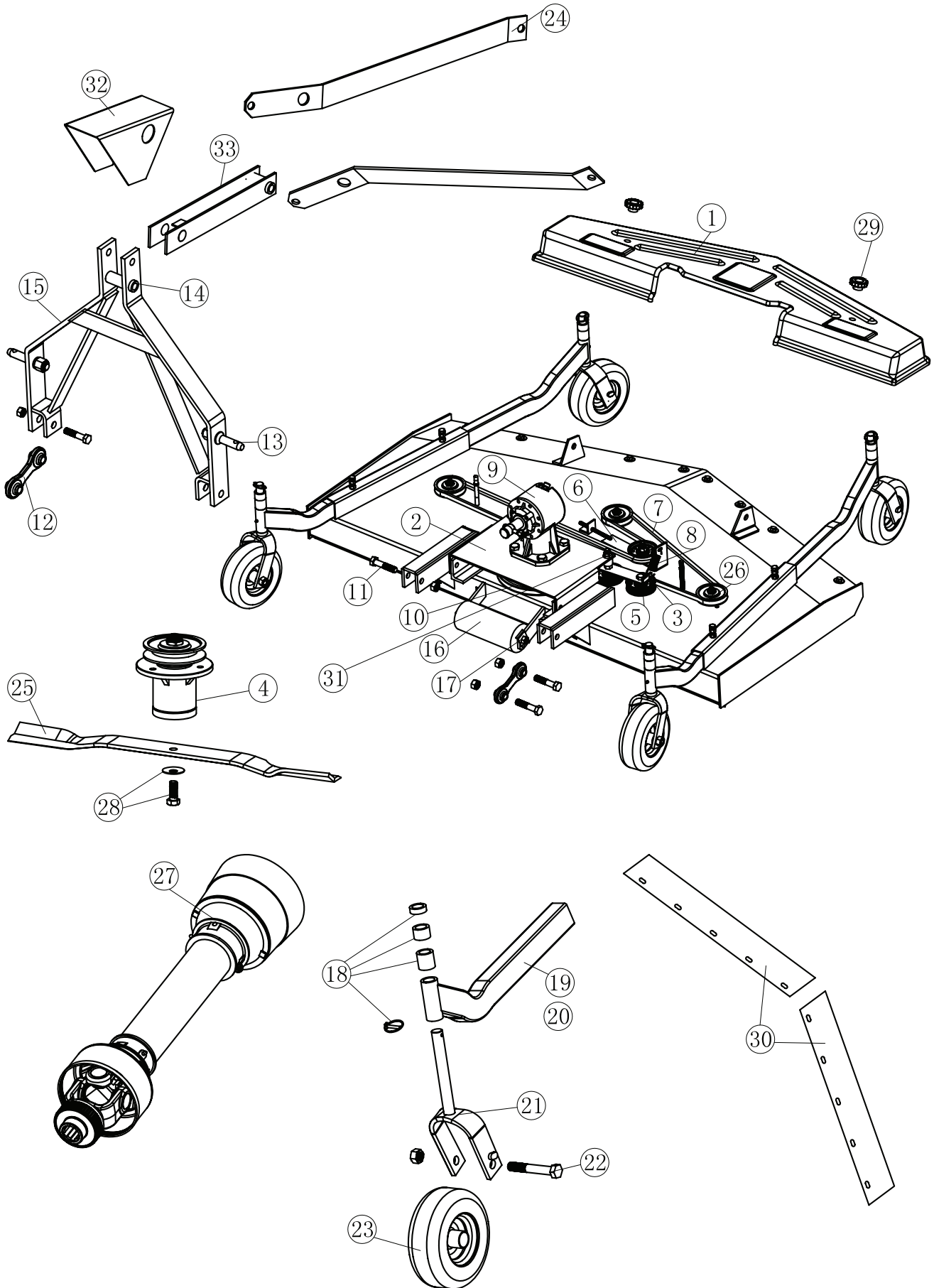

## Parts List

Item Number	5' Part Number	6' Part Number	7' Stainless Part Number	Description
1	124685	124686	124687	Top Cover
2	403025	403025	403025	Gearbox Plate
3	312647	312647	—	Idler Pulley Bracket
3	—	—	312641	Double-Idler Pulley Bracket
4	502303	502303	—	Spindle Unit - Single
4	—	—	502304	Spindle Unit - Double
5	164090	164090	—	Idler Pulley - Single
5	—	—	164091	Idler Pulley - Double
6	403688	403688	403688	Belt Adjustment Assembly
7	167133	167148	—	V-Belt*
7	—	—	167163	V-Belt Double
8	502027	502027	502027	Spring
9	184000	184000	184005	Gearbox
10	165114	165112	165112	Main Pulley - Single
10	—	—	165113	Main Pulley - Double
11	502011	502011	502011	Swivel Link Bolt Pkg 3/4" x 4" w/Nut
12	502010	502010	502010	Swivel Link Set
13	500001	500001	500001	Category I Lift Pins (2pk)
14	501095	501095	501095	Lift Arm Spacer w/Bolt & Nut
15	403664	403664	403664	Lift Arm Assembly
16	502110	502110	502110	Center Roller w/Axle
17	403670	403670	403670	Roller Axle
18	502120	502120	502120	Height Adjuster Set
19	403410	403410	403410	Front Tailwheel Arm
20	403415	403415	403415	Rear Tailwheel Arm
21	403023	403023	403023	Wheel Fork
22	502125	502125	502125	Axle Bolt 3/4" x 5" w/Nut
23	502020	502020	502020	Tire & Rim w/Axle & Nut
24	310066	310065	310065	Brace Arm
25	502320	502324	502328	Blade Set w/Bolts
26	502313	502313	—	Spindle Pulley - Single
26	—	—	502314	Spindle Pulley - Double
27	147022	147022	147022	22" PTO Shaft
28	502310	502310	502310	LH Blade Bolt Set w/Washer
29	502287	502287	502287	Plastic Knob
30	502401	502402	502403	Belt Guards (1-LH, 1-RH)
31	502197	502197	502197	Gearbox Plate Bolt Package
32	501029	501029	501029	Pivot Shield Kit
33	401031	401031	401031	Pivot Bar

# WARRANTY

Many replacement parts that your store currently provides will fit our implements, including but not limited to: tailwheels, blades, blade bolts, gear boxes, and category pins.

The manufacturer offers a 1-year manufacturers defect warranty on all non-commercial use of standard and sub-compact products. Any use by commercial, state, and municipalities will void warranty. Please contact your dealer to initiate all warranty claims.

Warranty specifications:

- Must show proof of purchase within 1 year of purchase date.
- Photos must be provided to ensure proper warranty claim.

The above information must be provided in order for us to process your claim and for you to receive a Return Manufacturers Authorization # (RMA) from the manufacturer. Any product determined to be defective and has been issued an RMA # by the manufacturer will be picked up by the manufacturer and returned to our facility for complete inspection. Once a warranty claim is accepted, the manufacturer will issue full credit or exchange the product at no cost to the store or customer.

Warranty limitations:

- Normal wear items are excluded from the manufacturer's warranty.
  - Normal wear parts include but are not limited to: tailwheels, blades, blade bolts, belts, shear pins, category pins, etc.
- No claim will be accepted for improper gear box or tailwheel lubrication, as recommended by manufacturer.

If you have questions concerning our warranty program or any questions concerning our products, please contact your dealer.



