

CENTRIFUGAL FERTILIZER SPREADER MOD. P - PL

OWNERS' MANUAL

⚡ Read the Operator's manual entirely before using the machine ⚡



CENTRIFUGAL FERTILIZER SPREADER MOD. P - PL

OWNERS' MANUAL

⚠ Read the Operator's manual entirely before using the machine ⚠

STATES UNDER ITS OWN RESPONSIBILITY THAT THE MACHINE

TYPE	CENTRIFUGAL FERTILIZER SPREADER
MODEL	P - PL
SERIAL NUMBER	
MANUFACTURING YEAR	

is in keeping with the European Union law:

98/37/CE

(that abrogates and includes the rules 89/392/CEE, 91/368/CEE, 93/44/CEE e 93/68/CEE)

For the machine's adjustment the following normative laws have been used:

EN 1553 1999

EN 14017 2001

and also the following technical specifications:

ISO 11684

Cosmo is Custodian of Technical File, that is placed in Via Laghi di Avigliana, 117 - 12022 BUSCA (CN)

Italy.

Place and Date of issue (Day/Month/Year)

SIGNATURE

INDEX

1. INTRODUCTION	6
2. GENERAL INFORMATION	6
2.1. USING THIS MANUAL	6
2.2. INFORMATION ON THE MACHINE	7
2.2.1. NAME PLATE	7
2.2.2. CHARACTERISTICS OF THE MACHINE	7
2.2.3. TERMINOLOGY	9
2.2.4. TECHNICAL DATA	9
3. IMPORTANT SAFETY INFORMATION	10
3.1. SAFETY SIGNALS	14
4. CONNECTIONS	15
4.1. CHECK THE RAISING ABILITY OF THE TRACTOR	15
4.2. CONNECTION TO THE 3-POINT HITCH OF THE TRACTOR	16
4.3. DRIVELINE INSTALLATION	16
5. FERTILIZER SPREADER USE	17
5.1. ADJUSTMENTS	18
5.1.1. HOW TO ADJUST THE SPREADER VANES	18
5.1.2. HOW TO ADJUST THE SPREADING	19
5.2. HOPPER LOAD	20
5.3. SPREADING OF THE FERTILIZER IN THE FIELD	20
5.3.1. SPREADING MISTAKES	22
6. GENERAL MAINTENANCE	23
6.1. LUBRICATION	24
6.2. REPLACEMENT OF THE SPREADER VANES	24
6.3. STORAGE	25
6.4. SPARE PARTS	25
7. WARRANTY	26
8. PARTS BREAKDOWN	27

COPYRIGHT

The technical information of this manual must be considered strictly reserved.

It is forbidden text and illustrations' reproduction.

Ediz. 03/2006

1. INTRODUCTION

The pendular spreaders are machines used for the distribution of solid, granular fertilizers and seeds in the field. They can be used whether with tractors of small/medium power.

It is recommended to carefully read this operator's manual of use and maintenance and follow the recommendations to help ensure safe and efficient operation with and on the machine.

This manual has been written, in order to give the customer all the information and safety rules on the machine, as well as use and maintenance instructions that let to make good use of the potentialities of the machine.

The manual must always be handy, so as to consult it, in order to check the operational cycle. If it gets lost or damaged, it will be necessary to ask for a substitutive copy.

In case of some difficulties of interpretation on texts or tables, or if the drawings/sketches are not clear enough, please get immediately in touch with the manufacturer or dealer of the machine for having all the clarifications through the experts in the working/maintenance or through the person who wrote the manual.

We are completely available for a real collaboration, in order to improve the understanding of the whole manual.

2. GENERAL INFORMATION

2.1. USING THIS MANUAL

This manual gives all the information for the use and maintenance of the machine. The good working and its life depends on the good maintenance and to the attention during the use.

Some pictures in this manual show details or accessories that could be different from those of your machine, some components could be removed, in order to assure the clearness of the pictures.

Some signal words are put on the machine and the operator shall see to keep them in a perfect visual condition, replacing them when they are not readable anymore.



The symbol on the left, joined to the words under shown:

DANGER!
ATTENTION!
WARNING!

are used in this manual to draw your attention on the safety and good work of the machine. Therefore, it is necessary to observe all the written rules.

We recommended to use the original spare parts and accessories.

The not original parts, besides to decline the guarantee, could be dangerous reducing the length and the performances of the machine.

2.2. INFORMATION ON THE MACHINE

The models introduced in this manual have been designed and made exclusively allowing the distribution of solid, granular fertilizers and of seeds in the field. The machine is not indicated for being used in different sectors from the agricultural one.

These machines are usually used during the day. If it is required the nocturnal use or with poor visibility, it must use the lighting system of the tractor or of the equipment to which the machine is connected.

A different use, like the above mentioned one is considered improper.

Any arbitrary modification made to this machine relieve the manufacturer from any responsibility for damages or lesions, also serious, that can be caused to the operators, to third parties or to things.

2.2.1. NAME PLATE

On the hopper of every machine, a name plate is fixed showing the model, the number of series and the year of construction of the machine.

When some spare parts are required, it is always necessary to refer to the type of machine, to the serial number and to the manufacturing year.

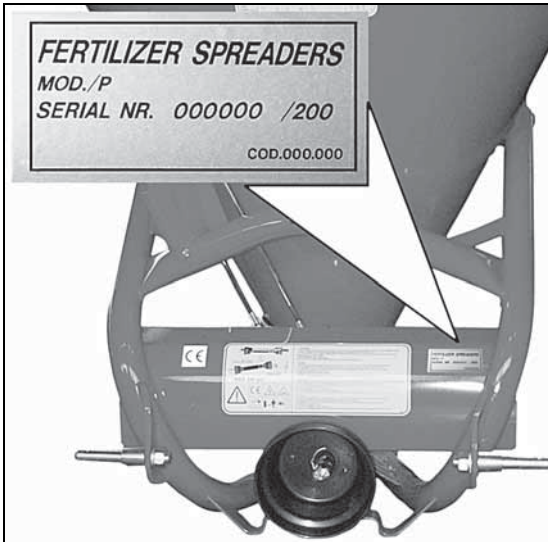

Location of the name plate on the machine

2.2.2. CHARACTERISTICS OF THE MACHINE

The great spreading precision lets them to be used in different applications , both for specific cultivations and in golf courses.

The pendulum spreaders series COSMO can rely on a huge range of models adaptable with tractors of any power.

The upper gear box devices are made in stainless steel in order to increase the corrosion resistance.

The gear box allows a width spreading adjustment from 9 meters (20 ft) to 15 meters that can be modified according to the needs and the kind of fertilizer used.

It is possible to settle the gear box on two different orders of spreading widths: from 9 to 12 meters or from 12 to 15 meters by using a special key. (see paragraph 5.1.1.)

Beside the standard gear box, several pendulum items are available for different applications, such as for the salt spreading in which the spreading width is limited from a minimum of 2 meters to a maximum of 4 meters, or for using it on the vineyards, the orchards or in the parks.

The fertilizer spreader P model has a distributor of fertilizer completely in stainless steel equipped with a spreader disc with four adjustable vanes in four different positions, in order to obtain the maximum spreading precision and uniformity in the distribution, depending on the kind of product that must be spreaded.



Spreader disc

The feeding of the disc is by gravity through an opening, located on the bottom of the hopper, inside of which a mix/agitator is applied, in order to prevent the fertilizer lumps formation. A sheet case is placed in front of the disc, in order to prevent the spreading in the front side of the machine.

The fertilizer delivery is controlled by properly opening of the orifices in the hopper bottom, through lock devices operated by levers.



Optional agitator

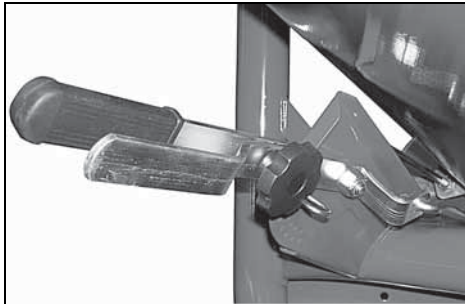

Lever system

The fertilizer spreader is connected through a gear box (1:1) with gears module 17 in order to be resistant, absorbing possible power stress.

The PL version has a plastic hopper instead of steel, perfectly interchangeable with all the models of P version.

On demand, it is possible to equip the machine with a lateral conveyor to be used for the spreading of the fertilizer in the orchard.

2.2.3. TERMINOLOGY

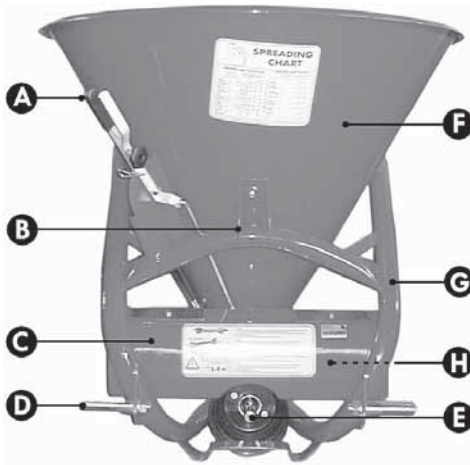

- A. Regulating lever
- B. Third hitch point
- C. Sheet case
- D. Hitch pin
- E. Pto shaft hitch
- F. Hopper
- G. Steel frame
- H. Distributor vanes

2.2.4. TECHNICAL DATA

TECHNICAL CHARACTERISTICS					
	P125	P250	P300	P400	P500
HOPPER CAPACITY (litres /gallons) (Kg/lbs)	165/44 213/470	220/58 285/628	260/79 335/739	300/79 387/853	345/91 450/992
Weight of the machine (kg/lbs)	54/119	56/123	58/128	60/132	63/139
Loading height (meters/inches)	0.91/36	1.01/40	1.05/41	1.07/42	1.13/44.5
Hopper width (meters/inches)	0.90/35.43	1.00/39.37	1.05/41.33	1.08/52.71	1.11/43.89
Spreading width (meters/ft)					
Granular	12-14/39-46	12-14/39-46	12-14/39-46	12-14/39-46	12-14/39-46
Crystalline	6-7/20-23	6-7/20-23	6-7/20-23	6-7/20-23	6-7/20-23
Power required at 540 rpm (Kw/Hp)	8/6	8/6	8/6	8/6	8/6

3. IMPORTANT SAFETY INFORMATION

THE FOLLOWING SAFETY RECCOMENDATIONS ARE TO SAFEGUARD YOUR INCOLUMITY: THEREFORE IT IS NECESSARY TO READ THEM CAREFULLY, MEMORIZING AND ALWAYS APPLYING THEM.

The present warnings in this manual regard exclusively the allowed uses and reasonably foreseeable. All below instructions must be integrated by the common sense and by the experience of who works, indispensable measures to prevent accidents.

The machine must be used by a single operator. It is forbidden the use of the machine to under-ages.

All the listed instructions must be carefully respected.

Possible changes on the machine, not preventively authorized by the manufacturer (by written copy), exclude his responsibility.

Check the correct functioning of the machine, before every employment.

General advices

- Read carefully this manual before proceeding to start, operate, employ or maintenance on the machine.
- Watch, in addition to the warnings of this manual, all the safety, accident prevention rules and of general nature.
- The manual must always be handy, so as to consult it, in order to check working cycle and safety information. In case of loss or damage, it will be necessary to ask for a substitutive copy.



ATTENTION!

Any work of maintenance, regulation and cleaning must be done with the machine on the ground (in stable conditions), turning off the tractor engine and removing the key.

- Read carefully the safety signal words applied on the machine and follow the instructions. In case of wear and tear or insufficient readability of the safety signal words, clean them up or replace them, placing the signal words in the right position, as shown in paragraph 3.1.



ATTENTION! - WARNING!

The operator, during the period of use, maintenance, repair, handling or storing of the machine, must wear accident-prevention shoes and safety gloves. Moreover, if it is necessary he must wear suitable hearing protections such as earmuffs or earplugs, dust masks and protective glasses.

- During loading phase, there is the danger of powders inhalation produced by fertilizer mixing. It is suggested to use tractors with filters on the ventilation system of the cabin, to use suitable safety systems of breathing, like powder masks or masks with filter.

-
-
- The machine is designed for being used by a single operator who, during the use, must always stay in the stationing control on the tractor.
 - Never work with this machine if you are tired, sick or after having took drinks, drugs or medicines.



DANGER!

It is forbidden to climb or to transport somebody when the machine is in motion.
Do not let inside the hopper for any reason.

- Keep the machine cleaned up from foreign bodies (detritus, tools, miscellaneous), as they could damage the operations or the operator. Generally the fertilizers are rather corrosive. For this reason, it is important that any particle of the fertilizer stay in the machine for a long period of time. Clean the hopper and the distributor after each use of the machine.
- If during cleaning operations it is used air or water with pressure, it is necessary to wear glasses and safety masks keeping away possible persons or animals from the machine.
- Before connecting the machine to the tractor or to other self-moving means check that this is in good conditions and that brakes work correctly, especially if you work on sloping grounds.
- Switch off the machine from tractor only on a compact and level ground (with empty hopper), checking that the machine is stable.



WARNING!

During transport operations, stocking and employment of the fertilizers, the operators must follow all the label indications and particularly to the content of the written risks and the precaution suggestions.



ATTENTION!

The Manufacturer does not answer to possible damages caused by an improper and unforeseen use of the machine.

The Manufacturer is not responsible in case of:

- improper use of the machine, use by not trained staff;
- serious deficiencies in the foreseen maintenance;
- changes or not allowed interventions;
- use of not original or specific spare parts;
- total or partial inobservance of the instructions;
- inobservance of the common safety rules during work;
- unusual cases.

Connection of the machine to the tractor

- The third hitch point of the tractor and the fertilizer spreader must coincide or must be adapted.
- Make sure that the pto shaft is engaged in right way after every linkage operation of the machine and that it does not come uncoupled when the machine is lowered in order to fill the hopped up.



ATTENTION! DANGER!

Check that the protections of the pto shaft are complete and in good conditions.

- In case of breaking or deterioration of the pto shaft protections, please replace them immediately.
- When the machine is not linked to the power unit, the pto shaft must be placed on the appropriate support.
- The presence of the machine can influence the manoeuvrability of the tractor, in particular during transport.



ATTENTION!

Do not come, for any reason, between the tractor and the fertilizer spreader when the engine is running and the power take-off is on.

Operation of the machine

- Make a check of the machine before switching it on. Start to work only if the machine is in perfect conditions.
- Before using the machine, please be sure that all the safety devices are correctly placed and in good state; in case of breakdowns or damages to the protections, please replace them immediately.



ATTENTION!

During work, please be sure that for a radius of 50 meters there are not any person or animals. When you work in proximity of roads or public places, it is **ABSOLUTELY OBLIGATORY** to keep away persons and to increase the precautions.



ATTENTION!

Anybody who comes up to the machine is in a danger area, therefore he becomes "AN EXPOSED PERSON". The operator must prevent anybody to come into the danger area and to work with the maximum caution. If somebody comes up, please stop immediately the tractor engine.

- Before every use of the centrifugal spreader, please always check the wear of the vanes and of the spreader disc. Check that all the fixing components (screws, bolts etc.) are in and fixed.
- The machine must never be unattended when it is moving.
- Keep always the machine in good operating conditions and make regularly the maintenance.

Transfer on the road



ATTENTION!

Please follow scrupulously the Highway code in force in the country of use.
During moves on public roads, it is obligatory to empty the hopper.

- Remember that during moving on public roads, special attention must be done, besides to possible and special regulations noted on the registration book of the tractor, choosing an appropriate speed especially when the street is crowded, winding or sloping.
- If the spreader hides with its shape the back signalling lights of the tractor, it is necessary to put a lights bar and/or some back signalling signs.
- During the moving on the road, please clean tyres or the working mechanism, in order to avoid to dirty the feather edge with earth or other material.



ATTENTION!

During the moving on the road, the warning flasher, yellow or orange, assembled on the tractor must always be in function also during the day.



ATTENTION!

During transport with raised machine, please always check that the control lever of the rear lifter is locked, in order to avoid the accidental lowering of the machine.

3.1. SAFETY SIGNALS



ATTENTION!

Be sure that the safety labels are readable. Clean them up using a cloth, water and soap. Replace the damaged labels placing them in the right position, as subsequently described.

The safety signs on the machine supply the most important indications: their observance helps your safeness.



1. ATTENTION! Before making any operation on the machine, stop the engine of the tractor or of the self-moving means, remove the key, put on the parking brake and read carefully the operator's manual.



3. ATTENTION! Check the sense of rotation and the number of revolutions (540 rpm) of the tractor power before placing the pto shaft.



5. ATTENTION! - DANGER! Possible throwing of material and/or objects, please do not stop or come up to the machine. Keep a safety distance of 50 meters, at least, from the machine.



2. ATTENTION! DANGER of entangling and dragging. Do not put hands near the running gear box.



4. ATTENTION! DANGER of crushing. Do not stop between the machine and tractor when the tractor engine is running.



6. ATTENTION! DANGER of shearing. Do not approach limbs to the spreader disc when the machine is running.



7. ATTENTION! Use the individual Protection Devices, as required.

Where placing the safety signals on the machine

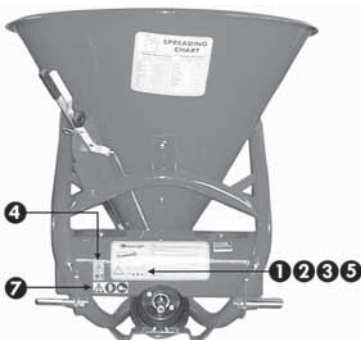

4. CONNECTIONS

Before coupling the machine to the 3-point hitch, positioning the safety devices to the tractor, so that it is not possible the involuntary and/or accidental raising and lowering of the arms.

The 3-point hitch of the tractor and of the machine must coincide or must be adapted.

In proximity of arms rods of the back lifter of the tractor, there is the danger of wounding, because of crushing and cutting points.

Do not use the external controls for the lifting of the machine.

During transport position block the lateral stop of the rods.

4.1. CHECK THE RAISING ABILITY OF THE TRACTOR



DANGER!

It is obligatory to check the raising ability and the stability of the tractor (before carrying out the connection with the machine) in order to avoid the overturning and/or the loss of wheels grip.

Check the raising ability and the stability of the tractor through the following formula and if it is necessary please apply some ballasts on the back.

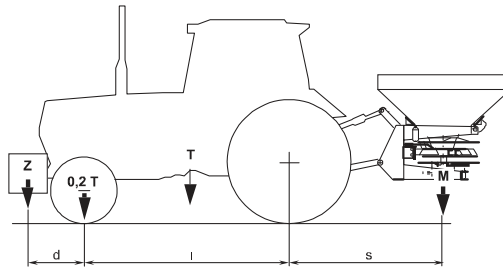

$$M \leq 0,2 T i + Z (d + i)$$

$$M \leq 0,3 T$$

i	=	Wheels base of the tractor
d	=	Distance of load ballast back axle
s	=	Bounce of the machine rear axle
T	=	Tractor load + 75 kg (operator)
Z	=	Load ballast
M	=	Machine load

4.2. CONNECTION TO THE 3-POINT HITCH OF THE TRACTOR



ATTENTION!

Every time that somebody comes down from the tractor, it is necessary to disconnect the pto shaft, stopping the engine and to put on the parking brake.

For the connection of the machine to the tractor, please operate in the following way:

- Step backwards with the tractor until arriving in proximity of the lower connections of the fertilizer spreader.
- Fix the lower connections of the tractor to the pins of the machine and lock them with the safety plugs.
- Connect the upper linkage of the machine to the 3-point hitch of the tractor putting the appropriate pin and block the anti-unscrewing device of the 3-point hitch;
- Raise the machine of some centimetres by the ground and operate on the lateral ties of the lifter bars and on the two turnbuckles, in order to block the lateral movement, so as to prevent excessive oscillations during the working phase.

The machine must be positioned, through the raising of the lower connections of the tractor, so that the land distance from the lower extremity of the distributor disc is approximately of 70 cm. To obtain a regular distribution, it is important that the distributor disc is in horizontal position compared to the land.

- After having made these operations, the pto shaft must be linked to the splined shaft of the gearbox of the machine (covered by a safety cowling) and after to the tractor power take-off.



ATTENTION!

The pto shaft must always be connected at last to the tractor power take off and disconnected at first, when you stop working.

4.3. DRIVELINE INSTALLATION

Before using the pto shaft, please consult the use and maintenance manual attached to the pto shaft.

In case that the pto shaft, supplied with the machine, is not used, please check that the cowlings of the machines and of tractors are overlapped to the pto shaft's shield of 5 cm., at least.

For a correct and safe operation of the machine, please use exclusively pto shafts with CE mark.

Please use pto shafts with integral shields.

- Grease periodically, the pto shaft following the instruction supplied by the pto shaft manufacturer (see the use and maintenance manual of the pto shaft).
- Observe the sense of assembly of the pto shaft, as indicated by the manufacturer and shown on the outer cover of the shield (tractor drawing on the external tube of the pto shaft towards the power take-off of the same tractor).

-
-
- Fasten the safety anti-rotation chains and make sure that the safety anti-removing block (push connecting ring nut) is correctly placed and blocked in the right lodging.



ATTENTION!

Check the rotation sense and the speed regulation of the power take-off of the tractor to be at 540 rpm, as the machine is projected for this kind of speed.

The length of the pto shaft must be adapted to the type of used tractor.

When the pto shaft is released from the power take-off of the tractor must ALWAYS be laid on the appropriate support.

COSMO Company is not responsible for the damages caused by an incorrect assembly and use of the pto shaft.

5. FERTILIZER SPREADER USE



ATTENTION!

Before use, please check that gears are adequately greased (see paragraph 5.1).



ATTENTION!

During the use of the machine, please be sure that for a radius of 50 meters there are not any person or animals. If somebody comes up, please stop immediately the tractor engine.

Recommendations for a correct distribution

- Please test always the kg/ha that you wish to spread before starting to work.
- Use a fertilizer in perfect conditions: a humid fertilizer could not be spreaded uniformly and correctly.
- Avoid to spread the fertilizer during windy days, in order to improve the uniformity of the distribution.

5.1. ADJUSTMENTS

It is not possible to have an exact spreading chart for equipments that make use of the centrifugal principle, given that the distributed quantity depends on the feed speed, on the radius of distribution, on the quality and humidity of the fertilizer and on the roughness of the land.

The fertilizer must always be stored and conserved adequately, so as to keep its physical characteristics unchanged.

It is necessary to set the speed of the centrifugal spreader, before starting the operation of distribution, trying, in the possible limits, to keep it constant for all its duration.

The spreading charts contain the indicative information, in order to determine the quantity to spread in the field; these must be completed by the experience and competence of the operator.

5.1.1. HOW TO ADJUST THE SPREADER VANES

In order to assure an homogenous distribution on both sides of the centrifugal spreader, depending on the different specific weight of the used fertilizer, the distributor vanes on the disc can have different positions.

When all the vanes are put in hole 1 (as shown in the picture), the distribution of the product is increased towards left, compared to the way of the tractor moving. On the contrary, if the vanes are put in hole 4, the distribution will be bigger towards right.

Moreover, moving the vanes from position 1 to position 4, at the same speed, there will be an increase of the distributing width of fertilizer distribution.

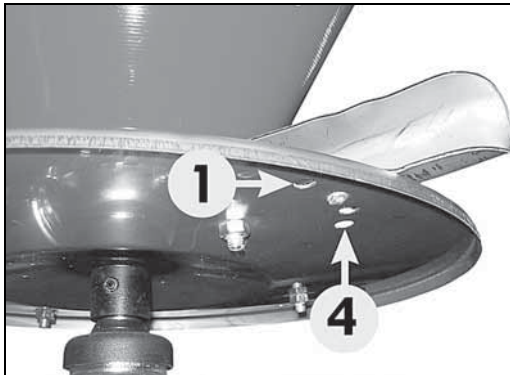

Regulation of the distributor vanes

This regulation must be made compared to the type of used fertilizer and to the experience of the operator.

5.1.2. HOW TO ADJUST THE SPREADING

The fertilizer spreading is regulated through the regulation lever that moves the opening section on the bottom of the hopper.

In order to carry out the regulation, after having consulted the spreading table, according to the type of product to spread and to the spreader speed, it is necessary to move the lever "A" along the graduated scale "E" and blocking it in the chosen position with the pin "D".

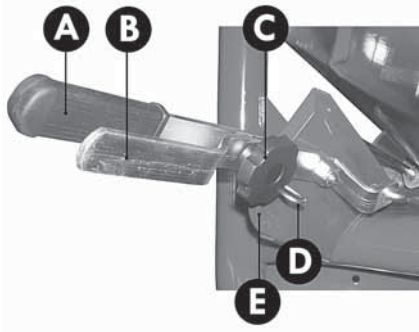

SPREADING CHART FOR FERTILIZER										SPREADING CHART FOR SEED									
SPEED		QUANTITY SPREAD IN LBS/ACRE								SPEED		QUANTITY SPREAD IN LBS/ACRE							
MPH	KPH	2	3	4	5	6	7	8	9	MPH	KPH	2	3	4	5	6	7	8	9
LARGE	2.5	122	205	402	626	929	1014	1540	1240	WHEAT	2	60	60	120	120	180	180	240	240
GRANULAR	5.0	60	123	251	378	465	507	570	624	MAIZE & CLOVER	2	60	60	120	120	180	180	240	240
FERTILIZER	7.5	40	82	124	212	210	238	260	430	BARLEY & WHEAT	2	60	60	120	120	180	180	240	240
MEDIUM	2.5	—	311	460	700	925	1025	1118	1182	RYE	2	60	60	120	120	180	180	240	240
GRANULAR	5.0	—	156	226	335	453	513	559	591	SOYBEAN	2	60	60	120	120	180	180	240	240
FERTILIZER	7.5	—	104	152	227	299	342	373	394	PEANUTS	2	60	60	120	120	180	180	240	240
FINE	2.5	112	189	322	529	747	842	963	1051	ALFALFA	2	60	60	120	120	180	180	240	240
GRANULAR	5.0	58	95	166	285	374	421	482	526	ORCHARD	2	60	60	120	120	180	180	240	240
FERTILIZER	7.5	37	62	111	177	240	269	321	351	GRASS	2	60	60	120	120	180	180	240	240
CRYSTAL	2.5	226	368	600	890	1236	1364	1523	1632	BARLEY	2	60	60	120	120	180	180	240	240
JARDON	5.0	113	184	320	485	618	677	761	816	WHEAT	2	60	60	120	120	180	180	240	240
SULPHATE	7.5	75	123	187	287	412	451	507	544	ORCHARD	2	60	60	120	120	180	180	240	240
THOMAS	—	—	—	—	—	—	—	—	—	BARLEY	2	60	60	120	120	180	180	240	240
MEAL	4.0	—	—	—	—	—	—	—	—	RYE	2	60	60	120	120	180	180	240	240
BRANDLAGE	8.0	—	—	—	—	—	—	—	—	—	—	—	—	—	—	—	—	—	—

In order to spread from both sides (ref. I), "A" and "B" levers must be in the same position, connected through grip handle "C".

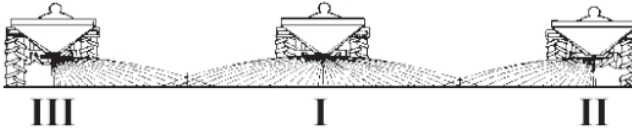

In order to carry out the spreading only through the left side (ref. II), it is necessary to disconnect the two levers removing the "C" grip handle, to set the lever "A" in the chosen position, given by the spreading chart, and to bring the lever "B" towards the higher part (position 1) in order to close the shutter of the right side.

In order to spread only on to the right side (ref. III) you have to move the lever "A" up, (in position 1) and regulate the quantity to spread with the lever "B".

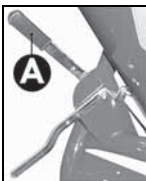

Distribution on right side (ref. III)

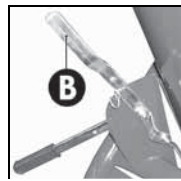

Distribution on left side (ref. II)



5.2. HOPPER LOAD

It is advised not to carry out the hopper loading manually but using a lifter or suitable mechanical means.



ATTENTION!

The hopper must be loaded only after having hitched the spreader to the tractor.

Do not drive for very long distances with a full load and do not put full bags on the fertiliser loaded in the hopper during the transport to the field or during the working, in order not to overload the capacity of the machine and to compress the fertilizer.



WARNING!

During the operations of transport, stock and use of fertilizers, the operator must be behaved in compliance with the indications on the label of the product and in particular with the content of the sentences of risk and the precaution advices.

5.3. SPREADING OF THE FERTILIZER IN THE FIELD



ATTENTION! - WARNING!

The operator, during the period of use, maintenance, repair, transport or storing of the machine, must wear accident-prevention shoes and gloves of security. If it is necessary, he will have, moreover, to wear headset, mask and glasses.

After having hitched the machine to the tractor and having carried out the necessary regulations, it is possible to begin to work.



ATTENTION!

Before getting off from the spreader and before every operation of maintenance and regulation, set in action the parking brake, turn off the engine, remove the ignition key from the dashboard and await the stop of all the moving parts.

5.3.1. SPREADING MISTAKES

Mistakes of use

- Drive speed;
- Incorrect spreading width;
- The spreading disc is not in a horizontal position compared to the land;
- Drive speed is different to those suggested by the spreading tables, or however not suitable for that particular type of fertilizer;
- Drive mistakes (lack of superimposition of the spreading surfaces);
- Lack of cleaning of distributing discs and the gates opening.

Mistakes due to the fertilizer

- Fertilizer of poor quality. Wet or excessive humid fertilizer;
- Incorrect fertilizer composition or it does not correspond to what declared from the vendor;
- Presence of excessive fertilizer lumps or with particular great dimensions that influence negatively on the yield of the spreading;
- Foreign body in the fertilizer.

Mistakes due to the spreader.

- Spreading exits clogged;
- Parts of the spreading disc worn away or damaged.

6. GENERAL MAINTENANCE

The ordinary maintenance criteria we suggest, are based on the company experience and on the advices and suggestions from our customers.

Such criteria are not exhaustive can be further integrated also with the collaboration of the customers that we thanks in advance.

A good ordinary maintenance keeps the operating costs of the machine low and provide an integral exploitation of its potentialities.



ATTENTION!

Whichever work of maintenance, regulation and cleaning must be carried out with the machine on the ground (in stable conditions), engine turned off, handbrake set, key of ignition off and removed from the ignition board.

In damage case, the operator must stop the machine immediately, assess the entity of the problem and proceed with eventual actions on the machine.

If pressure water or compressed air is used for the cleaning of the machine, it is necessary to protect oneself with proper glasses or protection masks and to remove eventual persons or animals near the machine. Do not use inflammable fluids.



ATTENTION!

For the maintenance operations, always use the fit Individual Protection Devices (accident-prevention footwear and gloves) and to prepare all the accident-prevention steps for the type of operation in course.



Every 8 hours of effective job, control the tightness of all nuts and bolts.

In case of anomalous vibrations, verify the status of wear of the vanes of the spreading disc, the corrected tightness of all the nuts and bolts and the lubrication of the gear box.

The excessive vibration of the machine, besides the specific annoyance, is dangerous and damaging for the entire structure subjecting the mechanical parts to more and more stress cycles compared to the advice pictures.

As regards particular actions that the user does not know or regarding broken parts replacing which are not shown in this manual, it is necessary to consult specialised personnel, making use of the Assistance service by the manufacturer or its distributors.

6.1. LUBRICATION

Before every use and after every 8 hours of effective work, carry out the greasing of the machine.

It is a good use that the greasing nipples are well cleaned up from mud or other residuals before using them for inject lubricating grease.

Lubricate with lithium grease the points, shown in the picture.

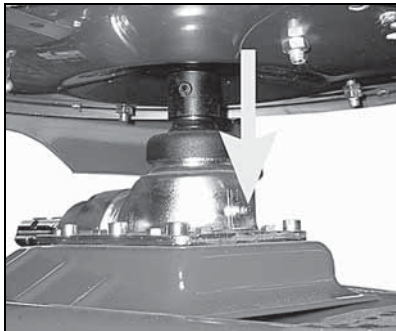

Point to grease

6.2. REPLACEMENT OF THE SPREADER VANES

In case the spreading vanes of the disc brake or get damaged, it is necessary to substitute them with new ones.



Unscrew the nut and replace the damaged vane.

The fixing items (nuts and bolts) must be of the same type of those prescribed from the manufacturer.

6.3. STORAGE

It is a good use not to wait for using the machine to carry out repairing and maintenance. To repair and to replace the parts that are broken or damaged before the storage, in order to have always the machine ready for being used.

To store the machine in a sheltered place away from atmospheric agents and protect it in order to avoid deteriorations.

The fertilizers are generally corrosive. For this reason it is important that no particles of fertiliser remains on the machine for long period of time.

Before storing the machine for long periods, it is opportune to operate as follows:

- wash accurately the machine and the inside of the hopper;
- to carry out a general control by sight of the machine in order to check eventual structural damages, to find eventual deep abrasions on the paint;
- to check that the safety signals are presents in their positions, that they are integral and readable, and in case they are deteriorated or unreadable, carry out immediately their substitution (see par. 3.1);
- to grease all the mechanical parts (to see par. 5.1);
- to store, if possible, the machine in a sheltered place.

6.4. SPARE PARTS

For the replacement of parts of the centrifugal spreader Mod. P-PL, the customer must use just original parts, ordering them directly to the manufacturer of the machine to authorized dealers.

Carrying out the order, it is necessary to specify what the identification label brings, in particular:

- serial number;
- model;
- manufacturing year;
- number of frame.

7. WARRANTY

All the manufactured machines, shown in this manual, are sold with one warranty valid for a year from the delivery date, subjected to the following clauses:

- ◆ In case a defect in a part is found (or in some parts) during a period of a year from the delivery date of the machine to the customer, the dealer commits himself to verify the defective part and, in case in the course of this verification it is assessed a defect which is due to the materials or to the manufacturing, he will repair the defective part or, to his discretion, to replace it free of charge.
- ◆ The customer, at the delivery, must control that the machine has not got damages during the transport, that is in compliance with the one ordered and that is complete with all the accessories got from the purchase contract. On the contrary, he must send a written claim within 8 days from its reception.
- ◆ The warranty is not applied in the following cases:
 - a) normal wear;
 - b) breaches or breaks deriving from negligence or due to the use of the machine in different conditions of the ones permitted;
 - c) in case the machine has got unauthorized modifications (in written document) from the manufacturer or if unoriginal spare parts and accessories were mounted;
 - d) when the serial number of the machine has been modified, removed or cancelled.

In any case, purchaser has to face the wearable parts substitution, the labour, transport costs, the eventual customs costs and the value-added tax.

Every responsibility for direct or indirect damages is declined when they are due to breaks or to the wear of the parts, the less for those deriving from the proper or improper use of themselves.

- ◆ Defects that are not clearly attributable to the material or to the manufacturing, will be checked by our Technical Attendance Centre or by our warehouse. If the claim would turn out unjustified, all the repair costs and/or substitution of the damaged parts will be debited to the purchaser.
- ◆ All the parts will be billed at the shipment time and at the eventual acknowledgment of the guarantees (previous receipt and check of the damaged parts). This will give the right to get the credit.

The manufacturer or its retailer will not be responsible of the loss, neither of the damage, whichever it is and in whichever way it happened during the transport.

The aforementioned commitment refers to the person of the customer and it cannot be yielded or be transmitted to others.

8. PARTS BREAKDOWN

Table 01

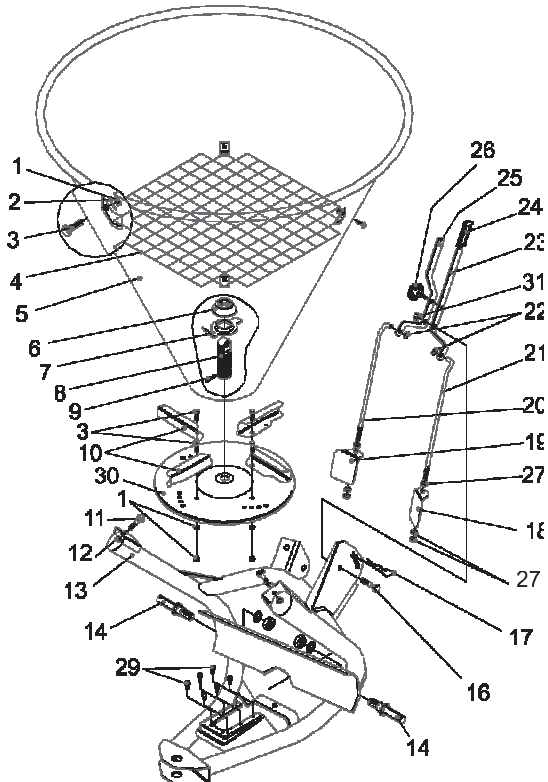

Table 02

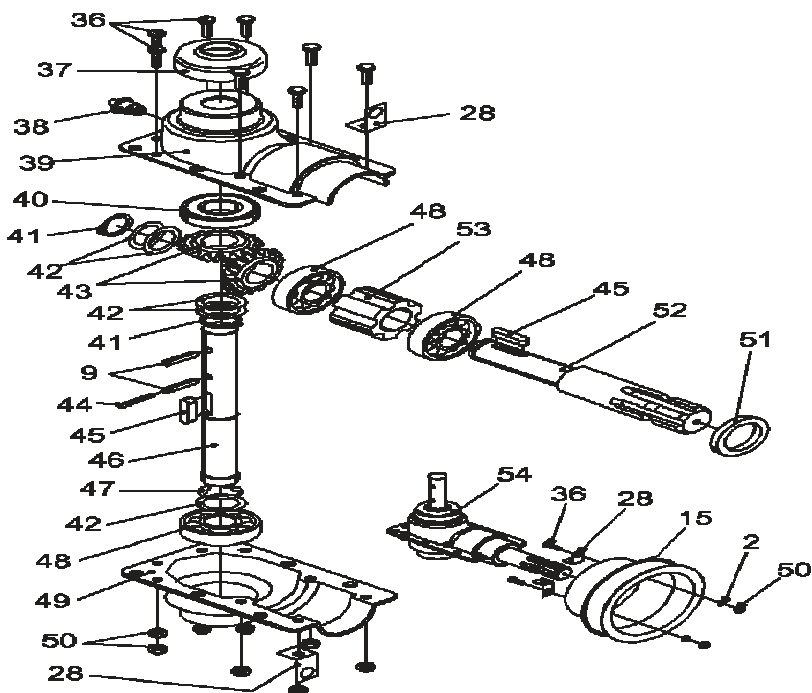
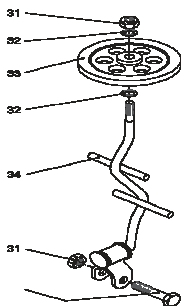

Table 03

Optional Agitator not included in the standard outfit of the machine, to use with powdered fertilizers only.



POS.	QTY	CODE	DESCRIPTION
1	4	301.012	NUT M8 UNI 5588
1	4	301.012	NUT M8 UNI 5588 for protective grate
2	4	303.007	WASHER 8X17 UNI 6592
2	4	303.007	WASHER 8X17 UNI 6592 for protective grate
3	4	300.030	ROUNDHEADED SCREW 8X16 UNI 5731
3	4	300.030	ROUNDHEADED SCREW 8X16 UNI 5731 for protective grate
4	1	642.001	PROTECTIVE GRATE
5	1	609.013	HOPPER 500
5	1	609.012	HOPPER 400
5	1	609.011	HOPPER 300
5	1	609.010	HOPPER 250
5	1	609.008	HOPPER 180
6	1	304.013	RUBBER RING
7	1	619.002	LOWER AGITATOR
8	1	330.001	ENTRAINER
9	2	305.001	SPRING PIN 8X40
10	4	601.001	DISTRIBUTOR VANE
11	3	300.023	ROUNDHEADED SCREW 10X20 UNI 5731
12	3	301.010	NUT M10 UNI 5588
13	1	613.003	NEW FRAME "P" without lower link pins
14	2	633.001	LOWER LINK PIN
15	1	304.006	CE SHIELD
16	1	300.024	HEXAGONAL-HEAD SCREW 12x35 UNI 5739
17	1	307.001	SPLIT PIN 4,5
18	1	605.004	LEFT SHUTTER
19	1	605.003	RIGHT SHUTTER
20	1	602.001	RIGHT TIE ROD
21	1	602.002	LEFT TIE ROD
22	2	303.009	WASHER 10,5X21 UNI 6592
23	1	604.002	LEFT LEVER
24	1	304.008	RUBBER GRIP
25	1	604.001	RIGHT LEVER
26	1	302.003	LEVER LOCK KNOB
27	6	301.014	NUT M10 UNI 5589
28	2	606.012	BRACKET FOR GEAR BOX "CE"
29	6	300.014	CHEESE-HEADED SCREW 8x16 UNI 5931
30	1	610.003	SPREADER DISC without distributor vanes
	1	610.001	SPREADER DISC with distributor vanes
	1	610.013	STAINLESS STEEL SPREADER DISC without distributor vanes
	1	610.014	STAINLESS STEEL SPREADER DISC with distributor vanes

POS.	QTY	CODE	DESCRIPTION
31	1+2	301.008	SELF LOCKING NUT M12
32	2	303.026	WASHER 13X25 UNI 6592
33	1	304.011	BUFFER WHEEL
34	1	613.009	UPPER AGITATOR FRAME
35	1	300.025	HEXAGONAL-HEAD SCREW 12x55 UNI 5737
36	8	300.026	HEXAGONAL-HEAD SCREW 6x16 UNI 5739
37	1	304.002	OUTPUT SHAFT COWLING
38	1	306.002	GREASE NIPPLE M8
39	1	314.002	UPPER SHELL
40	1	310.001	BALL BEARING 6205 2RS
41	2	313.011	SPING-LOCK RING
42	5	303.011	WASHER 25X35X0,5 DIN 988
43	2	316.003	PINION
44	1	305.003	SPRING PIN 5X40
45	2	326.003	SPLINE KEY 8X7X20 UNI 6604
46	1	323.009	OUTPUT SHAFT
47	1	313.010	SPLIT RING
48	3	310.002	BALL BEARING 6205
49	1	314.001	LOWER SHELL
50	8	301.009	SELF LOCKING NUT M6
51	1	309.001	OIL SEAL
52	1	323.008	INPUT SHAFT
53	1	329.011	SPACER
54	1	322.002	GEAR BOX
55	2	300.029	HEXAGONAL-HEAD SCREW 8X20 UNI 5739
56	5	301.012	NUT M8 UNI 5588
57	3	303.013	WASHER 8X24 UNI 6593
58	1	606.009	SUPPORT BRACKET
59	1	606.010	SHEET GUARD
60	1	311.001	PTO SHAFT RS1 510
		619.004	AGITATOR
		618.006	LEVER GROUP ASSEMBLED
		618.001	RIGHT LEVER ASSEMBLED
		618.002	LEFT LEVER ASSEMBLED
		301.015	SACK WITH BOLTS AND NUTS
		900.001	OWNER'S MANUAL SPARE PARTS
		206.004	GUARD FOR SPREADER DISC
		308.099	BIG COSMO LABEL
		308.107	SPREADING CHART KG.
		308.108	SPREADING CHART LBS
		308.109	LABEL FOR PTO SHAFT CARE
			NUMBER LABEL
		308.192	ROTATION CARE LABEL

TARTER[®]
FARM AND RANCH EQUIPMENT